

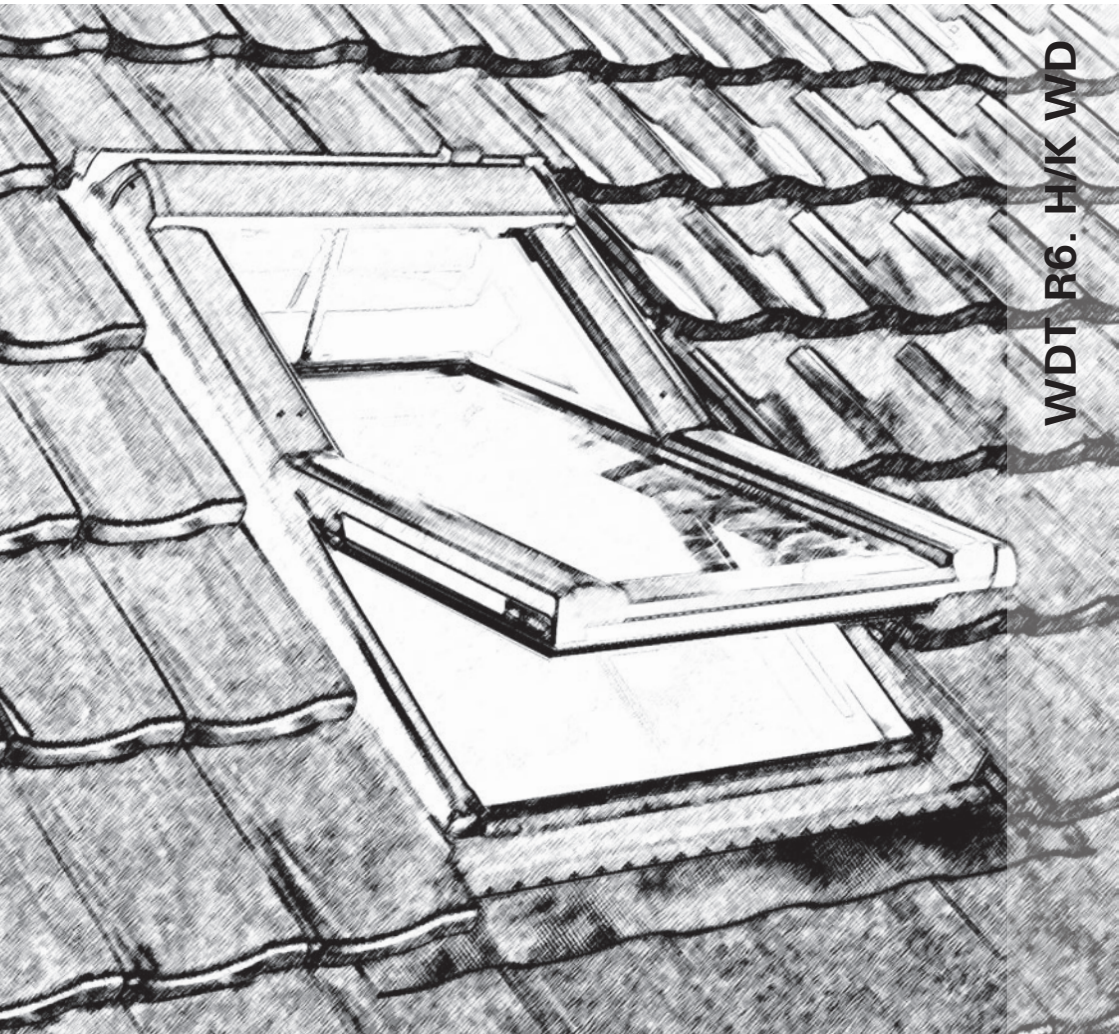

Einbauanleitung

Installation instruction



WDT R6. H/K WD



Deutschland

Hinweise/Sicherheitshinweise

- Bitte bewahren Sie die Anleitung auf!
- Die allgemeinen Unfallverhütungsvorschriften bei Dacharbeiten beachten.
- Die Baustelle gegen herabfallende Teile sichern.
- Bauphysikalische Grundlagen wie Wärmedämmung, Feuchteschutz, Regensicherheit/Wasserdichtheit und Lärmschutz beachten.
- Die Zahlen geben immer die Reihenfolge der Montage an!
- Technische Änderungen vorbehalten.

 Eingriffe in Tragwerkkonstruktionen dürfen nur von qualifizierten Fachkräften ausgeführt werden!

In Gebieten mit Schneefall ist oberhalb des Fensters eine Schneefangeinrichtung zu montieren.

Für Einbaulatten nur Holz der Sortierklasse S. 13 verwenden. Die Höhen der Dachlatten und die Höhe der Einbaulatten müssen gleich sein!

Verwenden Sie nur unveränderte Roto Originalteile.

Halten Sie Personen aus dem Fahrbereich der Anlagen fern!

Halten Sie Kinder von Steuerungen fern!

Beachten Sie Ihre landesspezifischen Bestimmungen.

Wird die Anlage durch einen oder mehrere Bedienelemente gesteuert, muß der Fahrbereich der Anlage während des Betriebs einsehbar sein.

Technischen Daten:

Steuerung

Nenneingangsspannung:	230 – 240 V AC / 50 – 60 Hz
Nennausgangsspannung M3:	230 – 230 V AC / 50 – 60 Hz
Zulässiger Ausgangsstrom M3:	1,5 A
Nennausgangsspannung M1, M2:	24 V DC
Zulässiger Ausgangsstrom M1, M2:	je 0,5 A
Schutzart:	IP 20
Betriebsklima:	0 bis +70°C max. 70% rel. H

Technischen Daten:

Antrieb

Druckkraft (max.):	300 N
Zugkraft (max.):	300 N
Laufzeit:	20s/ 100mm
Schutzart:	IP 50
Versorgung:	24 V DC / 0,5 A

(AC= Wechselspannung)

(DC= Gleichspannung)

(rel. H= relative Luftfeuchtigkeit)

France

Conseil/ Recommandation de sécurité

- Veuillez conserver ces instructions.
- Respecter le règlement général de prévention des accidents pour les travaux sur le toit.
- Assurer le chantier contre la chute de matériaux.
- Respecter les conditions de base relatives à la physique de bâtiment telles que isolation thermique, la protection contre humidité, contre la pluie/étanchéité à eau et protection contre le bruit.
- Les chiffres indiquent toujours l'ordre de montage !
- Sous réserve de modifications.

 Les interventions au niveau éléments porteurs ne doivent être réalisées que par une main-d'œuvre qualifiée!

Dans les régions avec chutes de neige, un pare-neige doit être monté au-dessus de la fenêtre.

Pour les lattes installation, utiliser exclusivement du bois sans noeuds et sans fissures. épaisseur des liteaux et épaisseur des lattes installation doivent être identiques!

Utiliser uniquement des pièces d'origine Roto non modifiées.

Tenir les enfants à distance de la zone de déplacement des installations.

Tenir les enfants à distance des commandes.

Respecter les prescriptions nationales.

Si l'installation est commandée par un ou plusieurs éléments de commande, la zone de déplacement de l'installation doit être bien visible pendant l'exploitation.

Caractéristiques techniques:

Commande

Tension nominale d'entrée :	230 – 240 V AC / 50 – 60 Hz
Tension nominale de sortie M3 :	230 – 230 V AC / 50 – 60 Hz
Courant de sortie admissible M3 :	1,5 A
Tension nominale de sortie M1, M2 :	24 V DC
Courant de sortie admissible M1, M2 :	0,5 A chacune
Type de protection :	IP 20
Climat de service :	de 0 à +70 °C max. 70 % rel. H

Caractéristiques techniques:

Motorisation

Force de pression (max.) :	300 N
Force de traction (max.) :	300 N
Temps de fonctionnement :	20 s/100 mm
Type de protection :	IP 50
Alimentation :	24 V DC/0,5 A



(AC= Tension alternative)
 (DC= Tension continue)
 (rel. H= Humidité relative de l'air)

 **Great Britain**
Safety advice/recommendations

- Please keep these instructions in a safe place.
- Observe the general regulations for prevention of accidents concerning work on the roof.
- Secure site against falling parts.
- Observe basics of building physics, as heat insulation, protection against moisture, rain shielding/water-proofness, and noise protection.
- The numbers specify the assembly sequence.
- We reserve the right to make any amendment.

 Work on the frame structure may only be performed by qualified personnel!

In areas with snowfall, protection or a deflector should be provided above the window.

For installation laths, use wood of the grading class MS 13/C35 only. The thickness of the roof battens and the thickness of the installation laths have to be identical!

Use only unmodified original Roto parts.

Keep children away from the operating range of power drives.

Keep children away from controllers.

Refer to the specifications in your national language.

If the equipment is controlled by one or more controls, the operating range of the equipment must be visible whilst operating the controls.

Technical data:

Controller

Nominal input voltages:	230 – 240 V AC / 50 – 60 Hz
Nominal output voltage M3:	230 – 230 V AC / 50 -60 Hz
Permissible output current M3:	1.5 A
Nominal output voltage M1, M2:	24 V DC
Permissible output current M1, M2:	0.5 A each
Index of Protection:	IP 20
Operating ambient conditions:	0 to +70°C max. 70% rel. H

Technical data:

Drive

Opening force (max.):	300 N
Closing force (max.):	300 N
Running time:	20 s / 100 mm
Index of Protection:	IP 50
Power supply:	24 V DC / 0.5 A

(AC= Alternating Current)
 (DC= Direct Current)
 (rel. H= relative atmospheric Humidity)



Nederland/Belgique Veiligheid/aandachtspunten

- Bewaar de handleiding.
- U dient bij werkzaamheden aan/op het dak de algemene voorschriften ter voorkoming van ongevallen in acht te nemen.
- U dient de bouwplaats tegen neervallende delen te beveiligen.
- U dient de bouwkundige principes zoals warmte-isolatie, vochtwering, bescherming tegen regenwater/waterdichtheid en geluidswering in acht te nemen.
- De getallen geven altijd de volgorde van de montagewerkzaamheden aan!
- Technische veranderingen voorbehouden.

 Ingrepen in de draagconstructies mogen uitsluitend door daartoe gekwalificeerd personeel worden uitgevoerd!

In gebieden met sneeuwval moet boven het raam een sneeuwvanginrichting worden gemonteerd.

Voor inbouwlaten mag u alleen hout van sorteerklass S13 gebruiken. De hoogte van de daklaten en de hoogte van de inbouwlaten moeten gelijk zijn!

Gebruik uitsluitend ongewijzigde, originele onderdelen van Roto.

Houd kinderen buiten de actieradius van de installaties.

Laat kinderen niet aan de besturingen komen.

Neem de nationale bepalingen in acht.

Als de installatie door een of meer bedieningselementen wordt aangestuurd, moet de actieradius van de installatie tijdens werking kunnen worden overzien.

Technical data:

Besturing

Nom. ingangsspanning:	230 – 240 V AC / 50 – 60 Hz
Nom. uitgangsspanning M3:	230 – 230 V AC / 50 – 60 Hz
Toegestane uitgangsstroom M3:	1,5 A
Nom. uitgangsspanning M1, M2:	24 V DC
Toegestane uitgangsstroom M1, M2:	elk 0,5 A
Beschermingsgraad:	IP 20
Werkomgeving:	0 tot +70°C max. 70% rel. vochtig.

Technical data:

Aandrijving

Drukkracht (max.):	300 N
Trekkracht (max.):	300 N
Looptijd:	20 s / 100 mm
Beschermingsgraad:	IP 50
Voeding:	24V DC/0,5A

(AC= wisselspanning)

(DC= gelijkspanning)

(rel. H= relatieve vochtigheid)



España Consejo/recomendación de seguridad

- Por favor, conserve las instrucciones.
- Tenga en cuenta las prescripciones generales de prevención de accidentes para trabajos en el tejado.
- Asegure la obra contra objetos que pudieran caer.
- Tenga en cuenta los principios físicos constructivos tales como aislamiento térmico, protección contra la humedad, seguridad contra el agua y protección contra el ruido.
- Los números indican siempre el orden de montaje.
- A reserva de modificaciones.

 Cualquier modificación en los elementos estructurales debe ser realizada únicamente por personal especializado!

En las zonas donde se presentan nevadas debe montarse un dispositivo paranieves por encima de la ventana.

Utilizar únicamente madera de la clase de selección MS 13 para los listones que se desean. La altura de los listones del tejado y de los listones que se desean montar debe ser igual!

Utilice solamente piezas originales Roto no modifique.

No deje que los niños se acerquen al área de desplazamiento de la instalación.

No deje los controles al alcance de los niños.

Tenga en cuenta las disposiciones pertinentes de su país.

Si la instalación es controlada mediante uno o varios elementos de mando, debe poderse ver el área de desplazamiento de la instalación durante el funcionamiento.

Datos técnicos:

Mando

Tensión nominal de entrada:	230 – 240 V CA/ 50 – 60 Hz
Tensión nominal de salida M3:	230 – 230 V CA/ 50 – 60 Hz
Corriente de salida permitida M3:	1,5 A
Tensión nominal de salida M1, M2:	24 V CC
Corriente de salida permitida M1, M2:	0,5 A, respectivamente IP 20

Tipo de protección:

Condiciones del entorno para el

funcionamiento:

0 a +70°C

máx. 70% humedad rel.

Datos técnicos:

Accionamiento

Fuerza de presión (máx.):	300 N
Fuerza de tracción (máx.):	300 N
Tiempo de funcionamiento:	20 s / 100 mm
Tipo de protección:	IP 50
Alimentación:	24V CC / 0,5 A



(AC= *tensión alterna*)
 (DC= *tensión continua*)
 (rel. H= *humedad relativa de la atmósfera*)

Dados técnicos:

Automatismo

Força de compressão (máx.):	300 N
Força de tracção (máx.):	300 N
Tempo de abertura:	20 s / 100 mm
Grau de protecção:	IP 50
Alimentação eléctrica:	24 V DC / 0,5 A

(CA= *Corrente alternada*)
 (CC= *Corrente contínua*)
 (H. rel. = *humidade relativa*)

Portugal Conselhos/recomendações de segurança

- Guarde o manual.
- Cumpra com as normas gerais para a prevenção de acidentes.
- Proteja o local da construção contra a queda de quaisquer peças.
- Atenda aos princípios fundamentais fisicotécnicos da construção civil, tais como isolamento térmico, protecção anti-humidade, segurança pluvial/impermeabilidade à água e protecção contra a poluição sonora.
- Os algarismos indicam sempre a ordem da montagem!
- Sob reserva de modificações.

 A realização de toda e qualquer intervenção nos vigaamentos só está autorizada a pessoal especializado devidamente qualificado!

Em zonas com neve, é necessário montar um dispositivo colectador de neve por cima da janela.

Utilize exclusivamente madeira da classe de qualidade S 13 para as fasquias de montagem. Tanto as alturas das ripas do telhado como a altura das fasquias de montagem deverão ser idênticas!

Utilize apenas peças originais inalteradas Roto.

Mantenha as crianças afastadas da área de trabalho das instalações.

Mantenha os comandos fora do alcance das crianças.

Respeite os regulamentos específicos do seu país.

Se o instalação for controlada por um ou mais elementos de comando, a área de trabalho da instalação tem de estar visível durante o funcionamento.

Dados técnicos:

Comando

Tensão nominal de entrada:	230 – 240 V CA / 50 – 60 Hz
Tensão nominal de saída M3:	230 – 230 V CA / 50 – 60 Hz
Corrente de saída admissível M3:	1,5 A
Tensão nominal de saída M1, M2:	24 V CC
Corrente de saída admissível M1, M2:	cada 0,5 A
Grau de protecção:	IP 20
Ambiente de trabalho:	0 até +70 °C máx. 70 % H. rel.



Polska

Wskazówki/wskazówki bezpiecze stwa

Prosz zachowa instrukcj .

- Nale y przestrzega ogólnych przepisów
- bezpiecze stwa pracy przy robotach dachowych. Zabezpieczy miejsce budowy przed spadaj cymi cz ciami.
- Przestrzega przy monta u podstaw fizyki budowlanej takich jak: izolacja cieplna, ochrona przeciwwilgociowa, zabezpieczenie przed deszczem/ wodoszczelno i d wi koszczelno .
- Cyfry podaj kolejno monta u!
- Zmiany techniczne zastrze one.

Wszelkich ingerencji w konstrukcje no ne mog dokonywa wył cznie wykwalifikowani fachowcy!

W rejonach z opadami niegu nale y powy ej okna zamontowa dachow barrier przeciw niegow .

Do monta u stosowa wył cznie łaty z drewna o jako ci klasy I. Grubo łat dachowych i łat monta owych musi by identyczna!

Prosz stosowa tylko niezmienione cz ci oryginalne Roto.

Nie nale y zezwala dzieciom na zbli anie si do obszaru działania urz dze .

Nie nale y zezwala dzieciom na zbli anie si do urz dze steruj cych.

Nale y przestrzega krajowych przepisów bezpiecze stwa i monta u.

Je eli układ sterowany jest przez jeden element obsługi lub wi cej, urz dzenie musi by widoczne podczas pracy.

Dane techniczne:

Sterownik

Napi cie znamionowe wej cia: 230 – 240 V AC / 50 – 60 Hz

Napi cie znamionowe wyj cia M3: 230 – 230 V AC / 50 – 60 Hz

Dopuszczalne nat enie wyj cia M3: 1,5 A

Napi cie znamionowe wyj cia M1, M2: 24 V DC

Dopuszczalne nat enie wyj cia M1, M2: 0,5 A (ka de)

Rodzaj ochrony: IP 20

Zakres temperatur: 0 do +70°C
70% maks. wzgl dna wilgotno powietrza

Dane techniczne:

Nap d

Siła nacisku (max.): 300 N

Siła ci gu (max.): 300 N

Czas cyklu pracy: 20 s / 100 mm

Rodzaj ochrony: IP 50

Zasilanie: 24 V DC / 0,5 A

(AC= napięcie przemiennie)

(DC= napięcie stałe)



Россия/ Україна



Указания/рекомендации по безопасности

- Сохраняйте данную инструкцию!
- Ознакомьтесь с общими указаниями во избежание травматизма при работе на крыше:
- Обезопасьте строительную площадку на случай падения используемого материала / инструмента.
- При монтаже соблюдайте основные принципы из области строительной физики, такие как тепло-, паро-, гидро- и звукоизоляция.
- Цифры на рисунках показывают последовательность их монтажа!
- Производитель оставляет за собой право на внесение изменений.



Работы с несущими конструкциями здания и любые изменения в них могут производиться только квалифицированным персоналом!

В районах, где выпадает снег, установить поверх окна приспособление для удержания снега.

Для монтажных реек должна использоваться древесина первого сорта. Высота обрешетки (контрбруса) и высота монтажных реек должна быть одинаковой!

Просим применять только оригинальные части Roto.

Не позволяйте детям приближаться к зоне действия оборудования.

Не позволяйте детям приближаться к элементам управления.

Соблюдайте правила безопасности и монтажа.

Если система работает с одним или несколькими элементами управления, то устройство должно быть видимым во время работы.

Технические характеристики:

Система управления

Номинальное напряжение на выходе: 230-240 В AC/ 50-60 Гц

Номинальное напряжение на выходе M3: 230-240 В AC/ 50-60 Гц

Допускаемая сила тока M3: 1,5 А

Номинальное напряжение на выходе M1, M2: 24 В DC

Допускаемая сила тока на выходе M1, M2: 0,5 А (каждая)

Вид защиты: IP 20

Пределы температуры окружающей среды: от 0° до +70°C

Макс. относительная влажность: 70%

**Технические характеристики:****Привод**

Прижимное усилие (макс.):	300 Н
Тяговое усилие (макс.):	300 Н
Время работы:	20 с / 100 мм
Вид защиты:	IP 50
Питание:	24В пост.т. / 0,5 А

*(AC – переменное напряжение)**(DC – постоянное напряжение)*

Лубатud M3 väljundvool:	1,5A
Väljuv nominaalpinge M1, M2:	24 V DC
Lubatud M1, M2 väljundvool:	kummalegi 0,5A
Kaitseklass:	IP 20
Kasutustingimused:	0 kuni +70°C max. 70% rel. H

Tehnilised andmed:**Ajam**

Survejõud (max):	300 N
Tõmbejõud (max):	300 N
Tööaeg:	20 s / 100 mm
Kaitseklass:	IP 50
Toide:	24 V DC / 0,5 A

*(AC= vahelduvvool)**(DC= alalisvool)**(rel. H= suhteline õhuniiskus)***Eesti****Näpunäited/ohutusjuhend**

- Soovitame käesolev juhend õige kasutuse ja hoolduse meeldetuletamiseks alles hoida.
- Katusel töötades tuleb pidada kinni üldistest ohutustehnika eeskirjadest.
- Kaitsta objekt ülevalt kukkuda võivate materjalide ja tööriistade eest.
- Paigalduse käigus pidada kinni ehitusfüüsika põhialustest: lengiümbruse soojusisolatsioon, veekindlus, aurutõke seestpoolt, heliisolaatsioon.
- Numbrid juhise piltidel näitavad paigaldusetape järjekorda!
- Tootja jätab endale õiguse tehniliste muudatuste sisseviimiseks.



Katuse kandekonstruktsiooni võivad muuta ainult vastavat kvalifikatsiooni omavad töötajad!

Lumesajuga piirkondades tuleb monteerida akna kohale lumepüüdur.

Akna paigalduslattidena kasutada ainult 1. klassi puitu. Roovlattice ja akna paigalduslattice paksus peab olema võrdne!

Kasutage ainult Roto originaaldetaile.

Hoidke lapsi akent avavast/sulgevast mootorit eemal.

Hoidke lapsed puldist eemal.

Pidage silmas antud ala reguleerivad ning

analoogete seadmete paigaldamist reguleerivad kohalikke normatiivakte.

Kui puldist juhitakse üht või mitut seadet, siis kõik seadmed peavad nende tööprotsessi ajal näha olema.

Tehnilised andmed:**Juhtsüsteem**

Pealetulev nominaalpinge:	230 – 240 V AC / 50 – 60 Hz
Väljuv nominaalpinge M3:	230 – 230 V AC / 50 – 60 Hz

Latvija

Norādījumi/drošības norādījumi

- Lasīt saglabātajā instrukcijā.
- Jāievēro visprāta drošības darba pasākumi pie jumta darbiem.
- Nodrošināt, lai celtniecības vietu neapdraud kratošās konstrukcijas vai priekšmeti.
- Veicot montāžu jāievēro fizikas pamatlūkumi, tādā kā:
 - termoizolācija, aizsardzība pret mitrumu, nodrošinājums pret lietu un skaņas izolācija.
- Cipari norāda montāžas secību.
- Pieļaujamas tehniskas izmaiņas.

⚠ Jebkādas uzlabojumus nesošajās konstrukcijās var veikt tikai kvalificēti darbinieki!

Reģionos, kur sniega slānis virs loga ir jāizmanto sniega savienojums.

Montāžai lietot tikai pirmšerīgās kvalitātes koka lātas. Latu jumta lātojumā jābūt vienādiezumam!

Izmantojiet vienīgi nepārvēdotas Roto oriģināldetaļas.

Neielaist bērniem iekļūst pīrvietošanās sfērā.

Nelaist bērniem pie vadības ierīcēm.
Lasīt ievērotājus valsts pašos noteikumos.

Jāiekļūst tieši vadītājiem vai vairākiem apkalpes elementiem, iekļūst pīrvietošanās sfērā darbam jābūt pārskatāmam.

Tehniskie dati:

Vadības sistēma

Nominālais ieejas spriegums:	230 – 240 V AC / 50 – 60 Hz
Nominālais izejas spriegums M3:	230 – 230 V AC / 50 -60 Hz
Pieļaujamā izejas strāva M3:	1,5 A
Nominālā izejas strāva M1, M2:	24 V DC
Pieļaujamā izejas strāva M1, M2:	0,5 A
Aizsardzība:	IP 20
Darbošanas klimats:	0 līdz +70°C maks. 70% rel. H

Tehniskie dati:

Piedziņa

Spiedes spēks (maks.):	300 N
Vilces spēks (maks.):	300 N
Darbošanas laiks:	20 s / 100 mm
Aizsardzība:	IP 50
Spriegums:	24 V DC / 0,5 A

(AC= maiņstrāva)

(DC= līdzstrāva)

(rel. H= relatīvais gaisa mitrums)

Lietuva

Nurodymas/saugumo taisyklės

- Saugoti instrukcijā.
- Būtina ievērot darba sauguma priekšnosacījumus.
- Apsaugoti darba vietu no krentāniem elementiem.
- Laikāties statybinių norm reikalavimų šilumos izoliacijai, drėgmės izoliacijai, nepralaidumo lietaus vandeniui, garso izoliacijai.
- Skaitiniai paveikslai rodo montavimo eiliškumą.
- Galimi techniniai pakitimai.

⚠ Bet kokius pakeitimus lango konstrukcijoje gali atlikti tik kvalifikuotas personalas!

Vietose, kur sniega, virš lango pritvirtinti sniego sulaikymo taisyklės.

Jeigu, montuojant stogo langus, neužtenka atstumo tarp gegnių, stogo konstrukcijos perdarymas galimas tik iš tokios pat medienos kaip ir gegnės!

Prašome naudoti tiktaik nenaudotas ir originalias Roto detales.

Negalima leisti vaikų prie prietaisų.

Neleisti vaikams prisitarti prie valdymo įtaisų.

Reikia laikytis saugos bei montavimo taisyklių.

Valdant vieną ar daugiau elementų, tai ranga turi būti matoma veikimo metu.

Techniniai duomenys:

Valdymas

Nominālais ieejas spriegums:	230 - 240 V AC / 50 – 60 Hz
Nominālais izejas spriegums M3:	230 – 230 V AC / 50 -60 Hz
Leidžiama srov M3:	1,5 A
Nominālā ieejas strāva M1, M2:	24 V DC
Leidžiama išeinamoji srov M1, M2:	0,5 A (kiekviena)
Apsaugos tips:	IP 20
Temperatūras robežs:	no 0 iki +70°C
maksimālā leidžiama drėgmis:	70%

Techniniai duomenys:

Pavara

Sūlygio jėga (maks.):	300 N
Tempimo jėga (maks.):	300 N
Eigos laikas:	20 s / 100 mm
Apsaugos tips:	IP 50
Maitinimas:	24 V DC / 0,5 A

(AC= kintama įtampa)

(DC= nuolatinė įtampa)



Česká republika
Doporučení/bezpečnostní upozornění

- Dodržujte prosím návod.
- Dodržujte všeobecné bezpečnostní předpisy pro práci na střeše.
- Zajistěte staveniště proti případnému pádu dílů.
- Respektujte stavebně-fyzikální podklady týkající se tepelné izolace, ochrany proti vlhkosti, vodotěsnosti při dešti a snížení a ochrany proti hluku.
- Práce vždy vyjadřují jednotlivých kroků montáže!
- Technické změny vyhrazeny.

⚠ Zásahy do nosné konstrukce střechy mohou provádět jen kvalifikovaní pracovníci!

Ve snáhových oblastech je třeba nad oknem namontovat zařízení k zachycení sněhu.

Pomocné montážní laty musejí být z dřeva bez sukla a prasklin. Výška střešních lat a pomocných montážních lat musí být stejná!

Používejte jen neupravované originální díly ROTO.

Zamezte dětem přístup do pracovního prostoru za zařízení.

Uložte ovládací jednotku mimo dosah dětí.

Dbajte na špecifických předpis platných ve Vaší zemi.

Bude-li zařízení ovládáno jedním nebo více ovládacími, musí být během pohybu akční rádius zařízením opticky kontrolovatelný.

Technické údaje:
zařízení

Jmenovité vstupní napětí: 230 – 240 V AC / 50 – 60 Hz
 Jmenovité výstupní napětí M3: 230 – 230 V AC / 50 – 60 Hz
 Přípustný výstupní proud M3: 1,5 A
 Jmenovité výstupní napětí M1, M2: 24 V DC
 Přípustný výstupní proud M1, M2: až 0,5 A
 Druh ochrany: IP 20
 provozní podmínky: od 0 do +70°C
 max. 70% rel. vlhkost.

Technické údaje:
Pohon

Tlaková síla (max.): 300 N
 Tažná síla (max.): 300 N
 Doba chodu: 20 s / 100 mm
 Druh ochrany: IP 50
 Zásobování: 24 V DC / 0,5 A

(AC = Střídavý proud)
 (DC = Stejnoseměrný proud)

Slovenská republika
Pokyny/bezpečnostné upozornenie

- Dodržujte prosím návod.
- Dodržiavajte všeobecné bezpečnostné predpisy pre prácu na streche.
- Zabezpečte stavenisko proti prípadnému pádu dielcov.
- Rešpektujte stavebno-fyzikálne podklady týkajúce sa tepelnej izolácie, ochrany proti vlhkosti, vodotesnosti pri daždi a snežení a ochrany proti hluku.
- Práce vždy vyjadrujú postupnosť jednotlivých krokov montáže!
- Technické zmeny vyhrazené.

⚠ Zásahy do nosnej konštrukcie strechy môžu vykonávať len kvalifikovaní pracovníci!

V oblastiach so snežením sa musí nad okno namontovať prípravok na zachytávanie snehu.

Pomocné montážne laty musia byť z dreva bez uzlov a prasklín. Výška strešných lát a pomocných montážnych lát musí byť rovnaká!

Použíajte len neupravované originálne diely ROTO.

Zabráňte deťom prístup do pracovného priestoru zariadenia.

Uložte ovládací jednotku mimo dosahu detí.

Dbajte na špecifických predpis platných vo Vašej krajine.

Ak bude zariadenie ovládané jedným alebo viac ovládacími, musí byť počas pohybu akčného rádiu zariadenia opticky kontrolovateľný.

Technické údaje:
Riadiaci systém

Jmenovité vstupné napětí: 230 – 240 V AC / 50 – 60 Hz
 Jmenovité výstupné napätie M3: 230 – 230 V AC / 50 – 60 Hz
 Přípustný výstupný proud M3: 1,5 A
 Jmenovité výstupné napětí M1, M2: 24 V DC
 Přípustný výstupný proud M1, M2: až 0,5 A
 Druh ochrany: IP 20
 prevádzkové podmienky: od 0 do +70°C
 max. 70% rel. vlhkosť.

Technické údaje:
Pohon

Tlaková síla (max.): 300 N
 Tažná síla (max.): 300 N
 Doba chodu: 20 s / 100 mm
 Druh ochrany: IP 50
 Elektrické napájanie: 24 V = / 0,5 A

(AC = Střídavý proud)
 (DC = Jednosměrný proud)

Magyar Köztársaság Utasítások/Biztonsági el írások

- Kérjük rize meg a használati útmutatót!
- A tet fed munkáknál figyelembe kell venni a balesetvédelmi el írásokat.
- Biztosítsák a beépítés helyszínét, hogy az esetlegesen lehulló hulladék, illetve egyéb anyagok ne okozzanak balesetet.
- Vegyék figyelembe az épületfizikai alapokat, így a h szigetelést, nedvességvédelmet, vízzáróságot és zajvédelmet.
- A száмок mindig a szerelés sorrendjét mutatják.
- M szakı változtatások jogát fenntartjuk.

 A tartószerkezetekhez csak képzett szakemberek nyúlhatnak hozzá!

Ahol gyakran havazik, az ablak felett hófogót kell felszerelni.

A lécezéshez csak csomó és repedésmentes fát szabad felhasználni. A tet lécek és a segédlécek magassága megegyez legyen!

Használjon eredeti Roto alkatrészeket.

A gyermekeket tartsa távol a szerkezetek hatótávolságából.

Tartsa távol a gyermekeket a vezérlést !!

Kérjük vegye figyelembe az országára vonatkozó el írásokat!

Amennyiben a szerkezet egy vagy több vezérl elemen keresztül m ködtethet , a szerkezet hatótávolságának jól beláthatónak kell lennie a m kódés során.

M szakı adatok:

Vezérlés

Névleges bemeneti feszültség: 230 – 240 V AC /
50 – 60 Hz
Névleges kimeneti feszültség M3: 230 – 230 V AC /
50 – 60 Hz

Engedélyezett kimen
áramer sség M3: 1,5 A
Névleges kimeneti feszültség M1, M2: 24 V DC
Engedélyezett kimen
áramer sség M1, M2: egységenként 0,5 A
Védelmi osztály: IP 20
Üzemi h mérséklet: 0-tól +70°C-ig
max. 70%-os
relatív páratartalom mellett

M szakı adatok:

Motor

Nyomóér (max.): 300 N
Húzóér (max.): 300 N
Futási id : 20 s / 100 mm
Védelmi osztály: IP 50
Áramellátás: 24 V DC / 0,5 A

(AC = váltóáram)
(DC = egyenáram)

Slovenija Navodila

- Prosimo shranite navodila!
- Upošteвайте splošne predpise za varnost na strehi. Zavarujte gradbiš e pred padajo imi deli s strehe.
- Upošteвайте gradbeno fizikalne osnove, kot so toplotna izolacija, zaš ita pred vlago, varnost pred
- vdorom dežja/vode in zaš ita pred hrupom.
- Številke vedno kažejo vrstni red vgradnje!
- Pridržujemo si pravico do
- tehni nih sprememb.

 Posege na nosilni konstrukciji smejo izvajati le kvalificirani strokovnjaki!

Na obmo jih s snežnimi padavinami je potrebno nad okno montirati snegolov.

Za vgradne letve uporabljajte le les vrste S 13. Višina strešnih letev in vgradnih letev mora biti enaka!

Uporabljajte le nespremenjene originalne Roto dele.

Otrokom prepre ite dostop do podro ja odpiranja okna.

Otrokom prepre ite dostop do upravljanja okna.

Upošteвайте veljavne varnostne predpise.

Podro je odpiranja okna naj bo med upravljanjem v vašem vidnem polju.

Tehni ni podatki:

Krmiljenje

Nazivna vhodna napetost: 230 – 240 V AC /
50 – 60 Hz
Nazivna izhodna napetost M3: 230 – 230 V AC /
50 – 60 Hz

Dovoljena izhodna elektri na energija M3: 1,5 A
Nazivna izhodna napetost M1, M2: 24 V DC
Dovoljena izhodna elektri na energija M1, M2: po 0,5 A
Vrsta zaš ite: IP 20
Ozra je za delovanje: 0 do +70°C
maks. 70% rel. H

Tehni ni podatki:

Pogon

Pritisna sila (maks.): 300 N
Vle na sila (maks.): 300 N
as delovanja: 20 s / 100 mm
Vrsta zaš ite: IP 50
Napajanje: 24 V DC / 0,5 A

(AC = izmenični tok)
(DC = enosmerni tok)
(rel. H = relativna zračna vlažnost)



Italia

Consigli/Indicazioni di sicurezza

Per favore tenere in considerazione le istruzioni.

Durante i lavori sul tetto osservare le norme antinfortunistiche generali.

Assicurare il luogo di lavoro contro la possibile caduta di pezzi.

Osservare i principi fondamentali fisici di costruzione quali isolamento termico, isolamento per umidità, la protezione contro acqua piovana/impermeabilità all'acqua, la protezione acustica.

I numeri indicano sempre la sequenza di montaggio! Escluse modifiche tecniche.



Gli interventi nelle strutture portanti devono essere eseguite solo dal personale specializzato!

In zone nevose si raccomanda di montare un sistema paraneve sopra alla finestra.

Per le assicelle di montaggio utilizzare solo legno senza nodi ed incrinature. Le altezze dei listoni del tetto e le altezze delle assicelle di montaggio devono essere uguali!

Per favore utilizzare solamente accessori Roto originali e integri.

Tenere lontano i bambini dal campo di utilizzo dell'impianto.

Tenere lontano i bambini dalle centraline.

Considerare le direttive specifiche della Vs. nazione.

Se l'impianto sarà pilotato attraverso elementi singoli o plurimi, durante l'utilizzo, il campo di pericolo dell'impianto deve essere ben visibile.

Dati tecnici:

Controllore

Valore nominale tensione in entrata: 230 – 240 V AC / 50 – 60 Hz

Valore tensione in uscita M3: 230 – 230 V AC / 50 – 60 Hz

Corrente permessa in uscita M3: 1,5 A

Valore tensione in uscita M1, M2: 24 V DC

Corrente permessa in uscita M1, M2: je 0,5 A

Modo di protezione: IP 20

Clima d'utilizzo: da 0 fino a +70°C max. 70%, rel. H

Dati tecnici:

Azionamento

Forza di compressione (max.): 300 N

Forza di trazione (max.): 300 N

Durata: 20 s / 100 mm

Modo di protezione: IP 50

Alimentazione: 24 V DC / 0,5 A

(AC = Tensione alternata/di scambio)

(DC = Tensione continua)

(Rel. H = relativa umidità atmosferica)



Hrvatska/Bosna i Hercegovina Napomene/sigurnosne napomene

- Molimo sa uvajate uputstva.
- Pridržavajte se op ih propisa sigurnosti za radove na krovu.
- Osigurajte gradilište od dijelova koji mogu pasti s krova.
- Pridržavajte se gra evinsko fizikalnih osnova kao što su toplinska izolacija, zaštita od vlage, sigurnost od prodora kiše/brtvljenje i zaštita od buke.
- Brojevi ozna avaju redoslijed kod montaže!
- Pridržano pravo tehni kih izmjena.

⚠ Radove na nosivim konstrukcijama smiju izvoditi samo kvalificirani stru njaci!

U krajevima gdje pada snijeg treba iznad prozora montirati ure aj za zaštitu od snijega.

Za ugradbene letve upotrebljavajte samo drvo 1. klase. Visina krovnih letava i visina ugradbenih letava mora biti jednaka!

Upotrebljavajte samo neizmijenjene Roto originalne dijelove.

Držite djecu podalje od radnog podru ja motora.

Držite djecu podalje od upravlja kog sistema.

Pridržavajte se važe ih odredbi.

Ukoliko se ure ajem upravlja jednim ili više elemenata za upravljanje, radno podru je ure aja za vrijeme rada mora biti vidljivo.

Tehni ki podaci: Upravljanje

Nazivni ulazni napon:	230 – 240 V AC / 50 – 60 Hz
Nazivni izlazni napon M3:	230 – 230 V AC / 50 – 60 Hz
Dopuštena izlazna struja M3:	1,5 A
Nazivni izlazni napon M1, M2:	24 V DC
Dopuštena izlazna struja M1, M2:	je 0,5 A
Vrsta zaštite:	IP 40
Radna klima:	0 bis +70°C max. 70% rel. H

Tehni ki podaci: Pogon

Sila pritiska (maks.):	300 N
Vu na sila (maks.):	300 N
Vrijeme rada:	20 s / 100 mm
Vrsta zaštite:	IP 50
Napajanje:	24 V DC / 0,5 A

(AC= Izmjenična struja)

(DC= Istosmjerna struja)

(rel. H= relativna vlažnost zraka)



Romania Măsuri de siguran ă

- V rug m s p stra i instruc iunile!
- Respecta i măsurile de siguran ă valabile pentru lucrările pe acoperi .
- Asigura i antierul contra căderii oricăror obiecte de pe acoperi .
- Respecta i regulile impuse de fizica acoperi ului cum ar fi : termoizola ia, hidroizola ia, protec ia contra precipita iilor, protec ia contra umezelii i protec ia fonică.
- Numerele reprezintă întotdeauna ordinea!
- Ne rezervăm dreptul a face schimbări din punct de vedere tehnic.

⚠ Lucrările legate de structura de bază/siguran ă efectuate la acoperi se execută numai de către personalul calificat.

În rile cu z pad , deasupra ferestrei se va monta un dispozitiv de captare a z pezii.

Pentru stinghiile de fixare a se folosi numai lemn calitatea I . Înăl imea stinghiilor i al caroiajului trebuie să fie egală.

Folosi i numai piese originale, nemodificate, de la Roto.

Nu atinge i părțile mobile atât timp cât sunt în mi care.

Nu lăsa i telecomenzile la îndemâna copiilor !

Respecta i reglementările în vigoare specifice fiecărei ări în parte.

Atunci când se ac ioneaza unul sau mai multe motoare, mi carea acestora trebuie să poată fi controlată vizual.

Date tehnice :

Comanda

Tensiune intrare:	230 – 240 V AC / 50 – 60 Hz
Tensiune de lucru M3:	230 – 240 V AC / 50 – 60 Hz
Intensitate curent M3:	1,5 A
Tensiune de lucru M1, M2:	24 V DC
Intensitate curent M1, M2:	cate 0,5 A fiecare
Clasa de protecție:	IP 40
Temperaturi de lucru:	între 0 si 70 oC, umiditate relativă maxim 70 %

Date tehnice :

Ac ionarea

For a de presiune (max.):	300 N
For a de trac iune (max.):	300 N
Perioada de func ionare:	20 s / 100 mm
Clasa de protecție:	IP 50
Alimentarea:	24 V DC / 0,5 A

(AC = Curent alternativ)

(DC = curent continuu)



Greece

Συμβουλή/σύσταση ασφάλειας

- Παρακαλώ κρατήστε τις οδηγίες τοποθέτησης
- Τηρήστε τα γενικά προληπτικά μέτρα ασφαλείας για τις εργασίες σε οροφές κτιρίων.
- Ασφαλίστε το εργοτάξιο από τυχόν πτώση αντικειμένων.
- Λάβετε υπόψη τις βασικές φυσικές κατασκευαστικές αρχές, όπως η θερμομόνωση, η προστασία από την υγρασία, η προστασία από τη βροχή/ η υδατοστεγανότητα και η αντιθουρβική προστασία.
- Οι αριθμοί αντιστοιχούν πάντα στη σωστή σειρά τοποθέτησης!
- Με την επιφύλαξη τροποποιήσεων.

⚠ Οι επεμβάσεις στη φέρουσα κατασκευή επιτρέπεται να πραγματοποιούνται αποκλειστικά από εξειδικευμένο προσωπικό!

Στις περιοχές με χιονοπτώσεις πρέπει να τοποθετηθεί πάνω από το παράθυρο μια διάταξη συγκράτησης του χιονιού.

Για τις δοκούς τοποθέτησης χρησιμοποιήστε αποκλειστικά ξύλο της κατηγορίας ταξινόμησης S 13. Το ύψος των δοκών της οροφής και το ύψος των δοκών τοποθέτησης πρέπει να είναι το ίδιο!

Χρησιμοποιήστε μόνο γνήσια Roto εξαρτήματα.

Παρακαλώ παραμείνετε μακριά από το πεδίο κίνησης του παραθύρου.

Παρακαλώ κρατήστε τα παιδιά μακριά από τα χειριστήρια.

Προσέξτε τους κανονισμούς της χώρας σας.

Αν έχετε έναν ή περισσότερους κινητήρες θα πρέπει να προσέξετε, κατά την κίνηση τους να είναι εμφανές το πεδίο κίνησης.

Τεχνικά χαρακτηριστικά

Μονάδα ελέγχου

Όνομαστική τάση εισόδου:	230 – 240 V AC / 50 – 60 Hz
Όνομαστική τάση εξόδου M3:	230 – 230 V AC / 50 -60 Hz
Επιτρεπτό ρεύμα εξόδου M3:	1,5 A
Όνομαστική τάση εξόδου M1, M2:	24 V DC
Επιτρεπτό ρεύμα εξόδου M1, M2:	από 0,5 A
Βαθμός προστασίας:	IP 40
Συνθήκες λειτουργίας:	0 έως +70°C μέγ. 70% σχετική υγρασία αέρα

Τεχνικά χαρακτηριστικά

Κινητήρας

Δύναμη πίεσης (μέγ.):	300 N
Δύναμη εφελκισμού (μέγ.):	300 N
Χρόνος λειτουργίας:	20 s / 100 mm
Βαθμός προστασίας:	IP 50
Τροφοδοσία:	24 V DC / 0,5 A

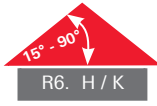

ZIN

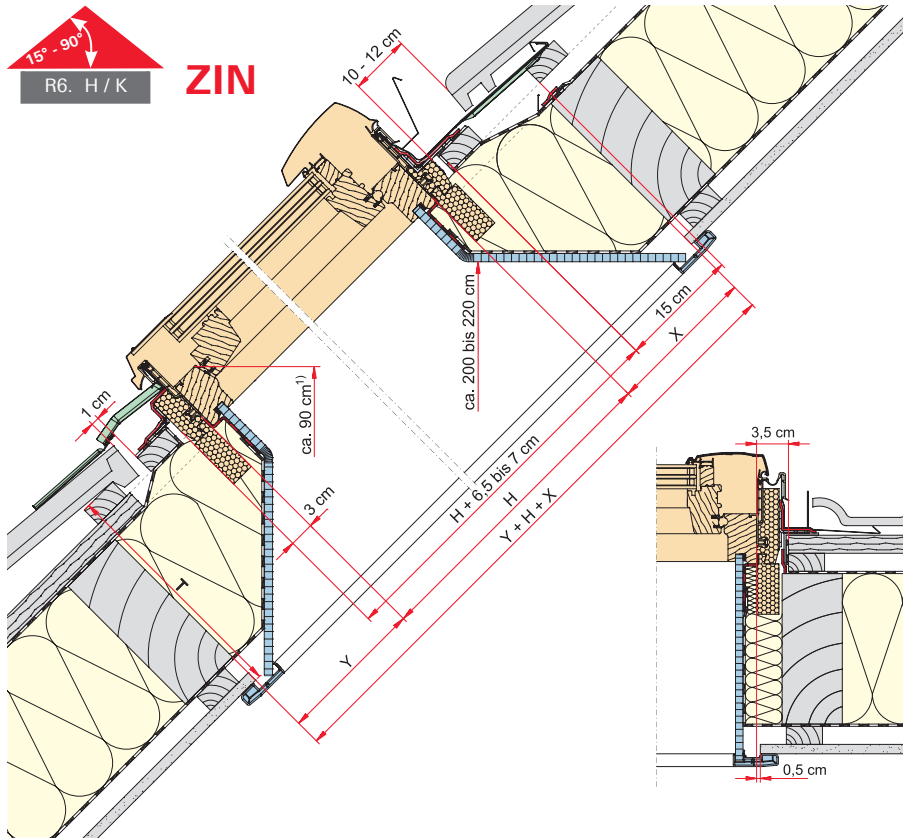

ZIN ▲		15°	20°	25°	30°	35°	40°	45°	50°	55°	60°	65°	70°	75°	80°	85°	90°
T = 26 cm	X	67	48	38	31	25	21	18	15	13	11	9	7	5	3	2	0
	Y	5	7	9	11	13	15	18	21	25	31	38	48	67	102	205	0
T = 28 cm	X	74	54	42	34	28	24	20	17	14	12	10	8	5	4	2	0
	Y	5	8	10	12	14	17	20	24	28	34	42	54	74	113	228	0
T = 30 cm	X	82	59	46	38	31	26	22	18	15	13	10	8	6	4	2	0
	Y	6	8	10	13	15	18	22	26	31	38	46	59	82	124	250	0
T = 32 cm	X	89	65	51	41	34	28	24	20	17	14	11	9	6	4	2	0
	Y	6	9	11	14	17	20	24	28	34	41	51	65	89	136	273	0
T = 36 cm	X	104	76	59	48	40	33	28	23	20	16	13	10	8	5	2	0
	Y	8	10	13	16	20	23	28	33	40	48	59	76	104	158	319	0
T = 40 cm	X	119	87	68	55	45	38	32	27	22	19	15	12	9	6	3	0
	Y	9	12	15	19	22	27	32	38	45	55	68	87	119	181	365	0



1

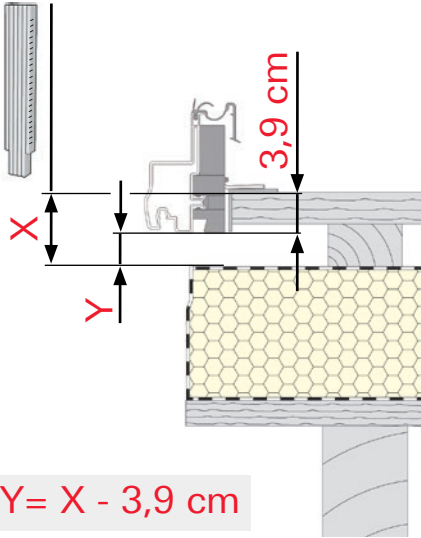

2

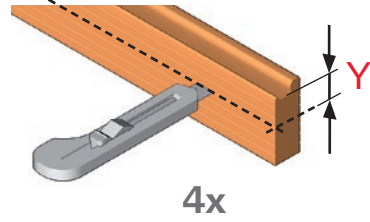

3

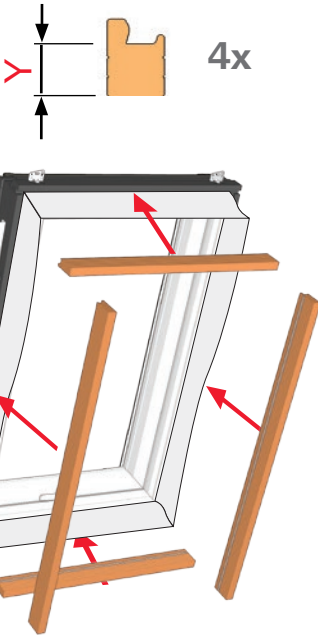

4

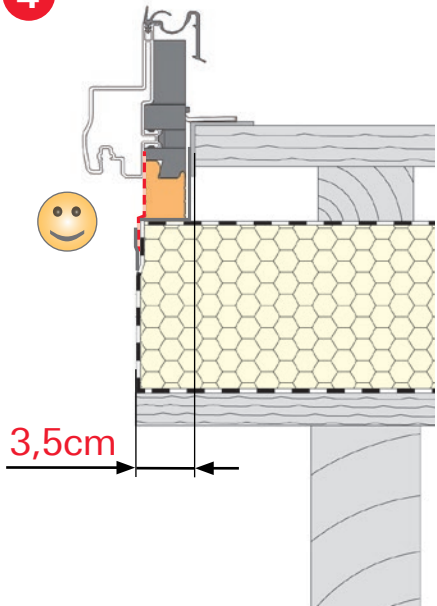



A
ø4,0 x30

B

C

D

E
RS

F

R6. K WD	16	4	1	3		
R6. K WD ≥ xx/16	20	6	1	3		
E					1	1
EF					1	

A
ø4,0 x30

B

C

D

E
RS

F

R6. H WD	16	4	1	3		
R6. H WD ≥ xx/16	20	6	1	3		
E					1	1
EF					1	

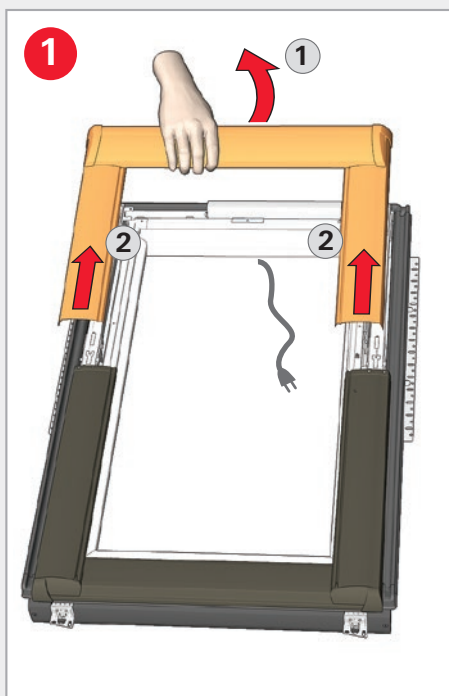
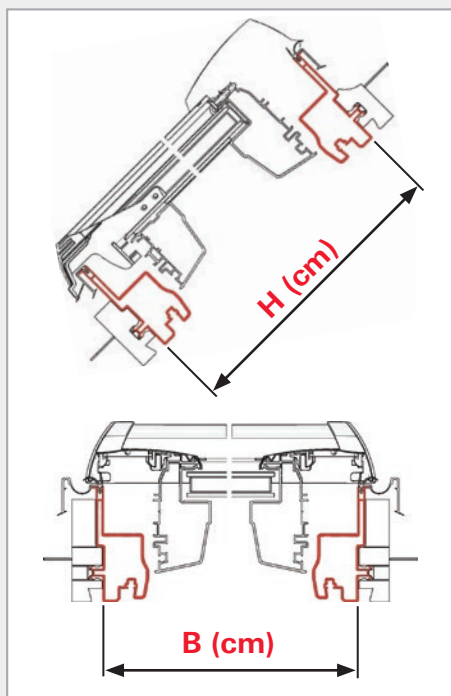
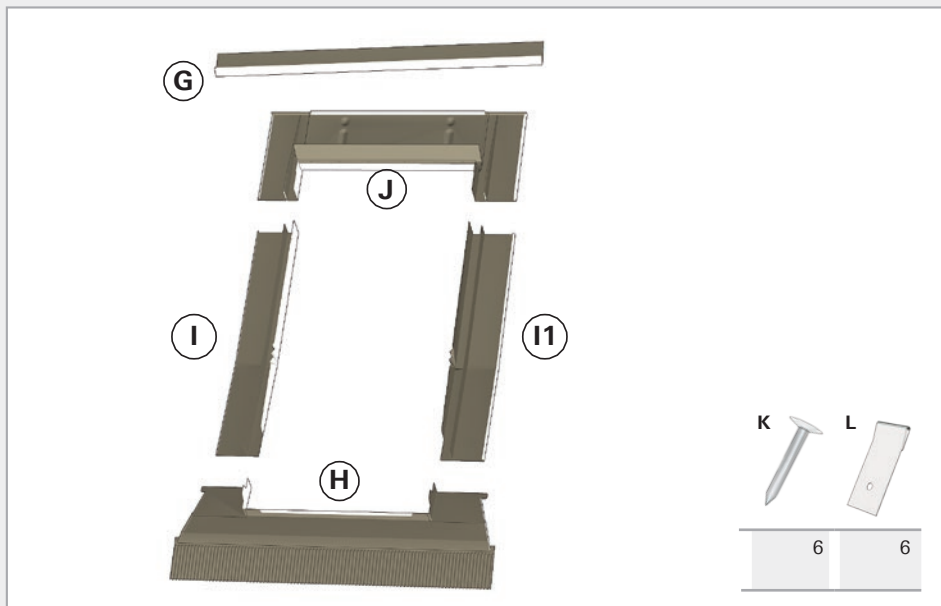

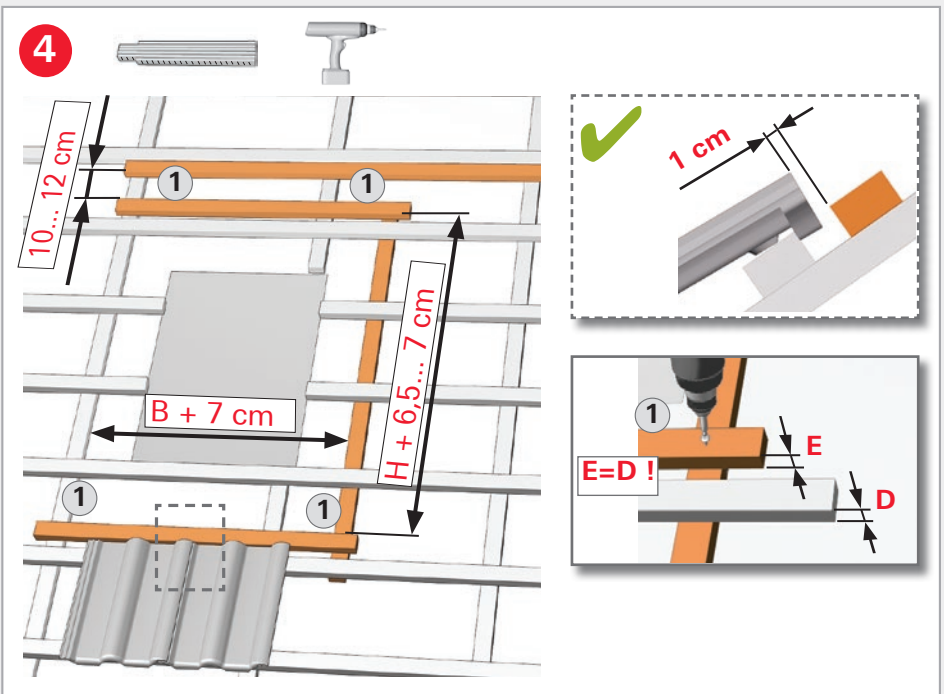
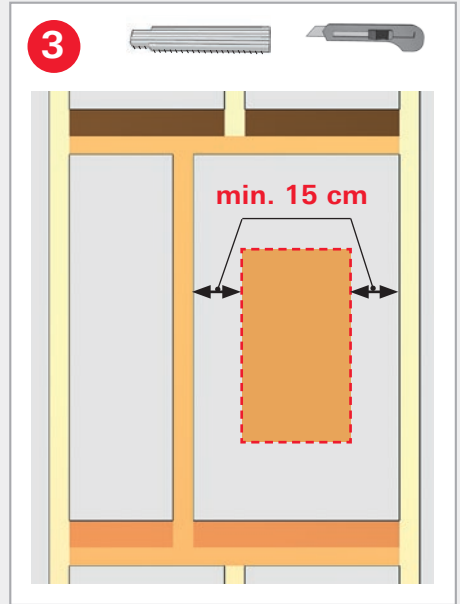
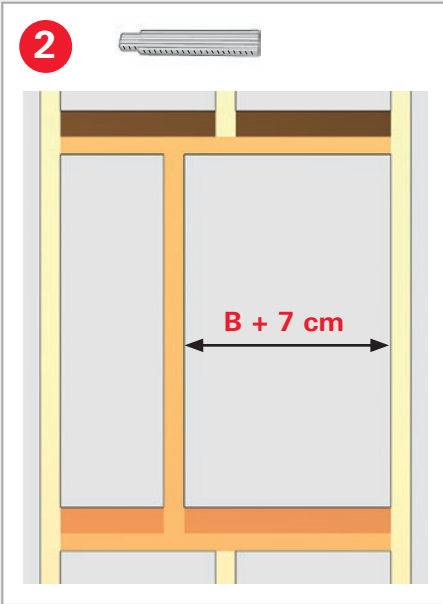

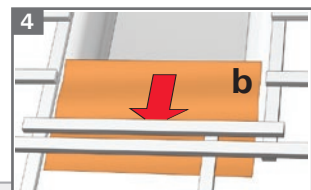
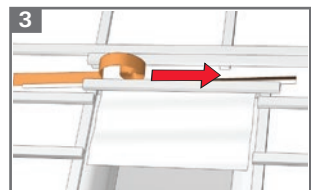
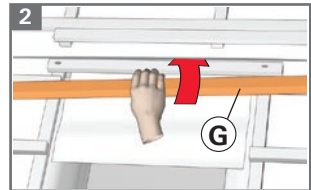
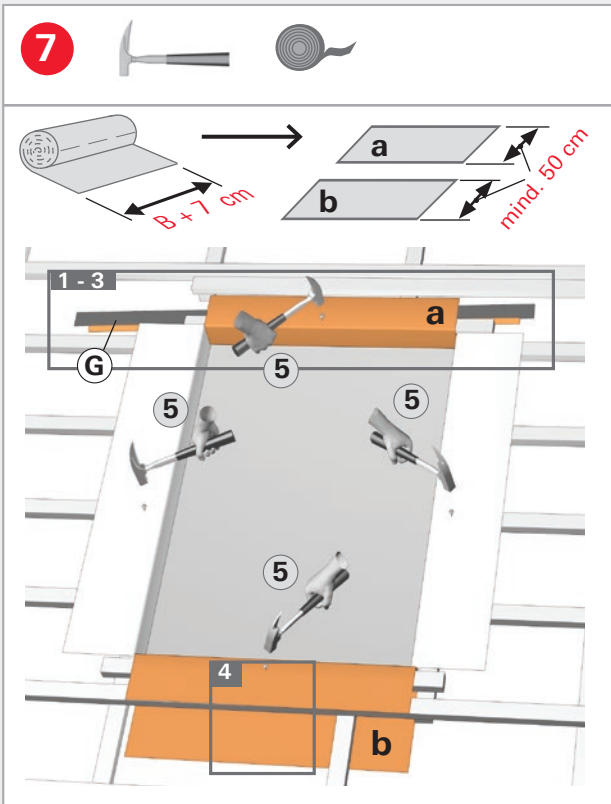
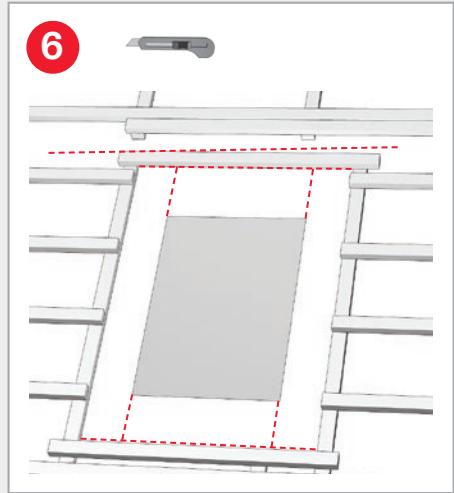
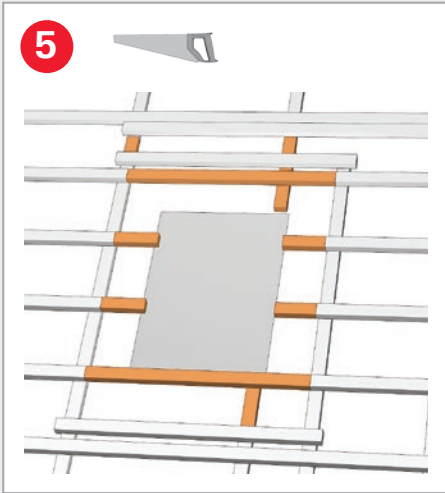

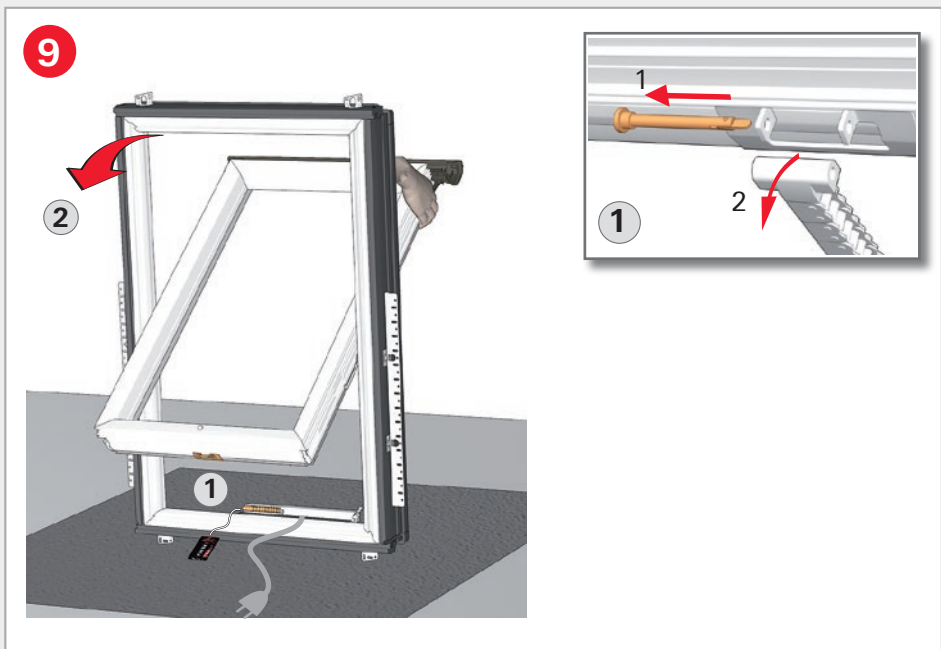
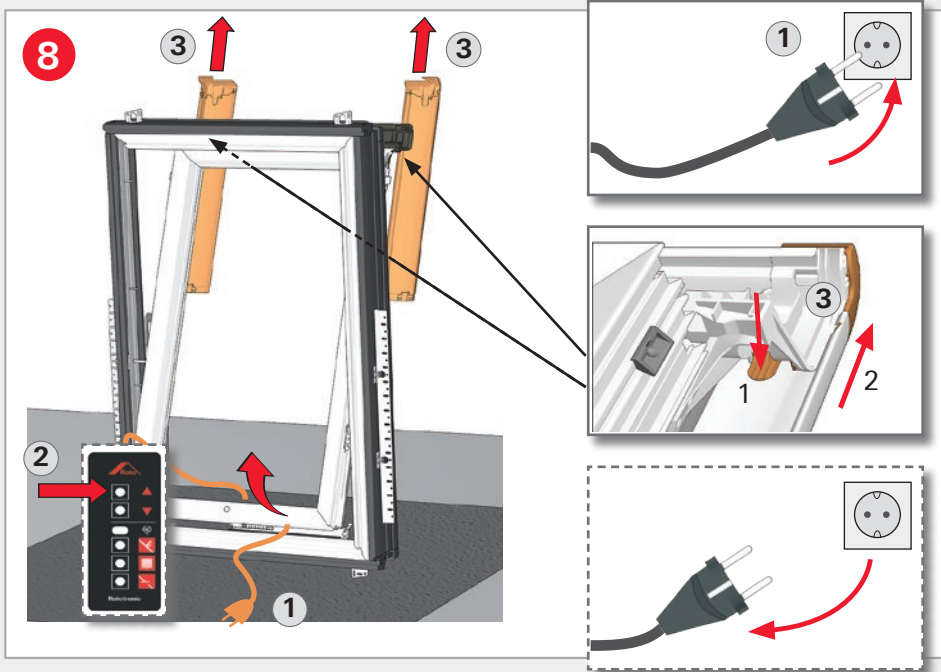

10

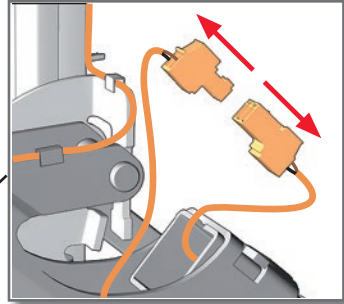
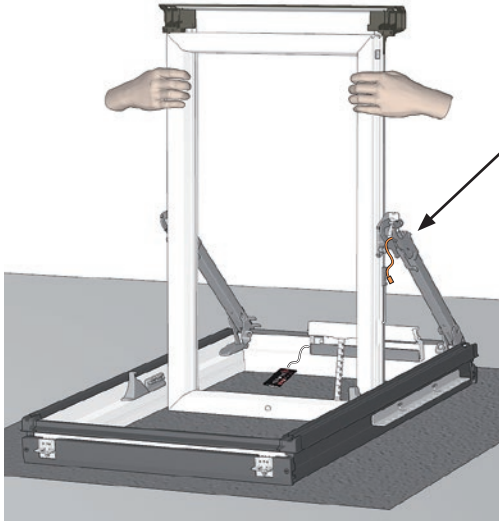

11

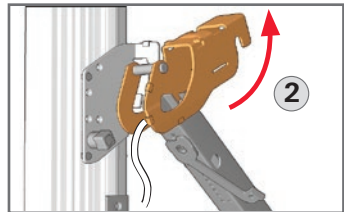
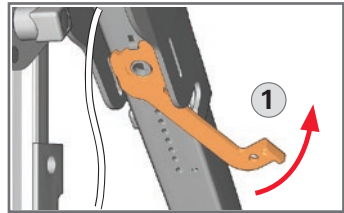
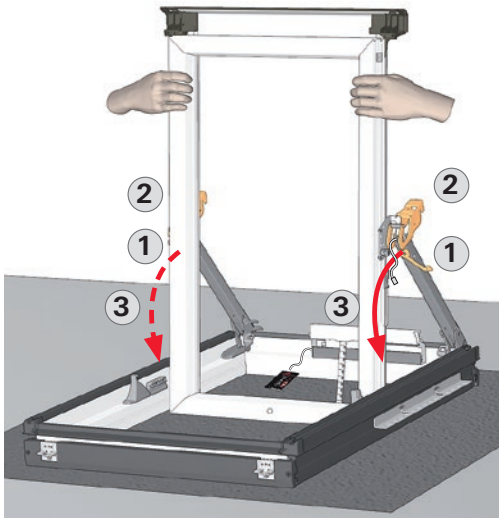

12

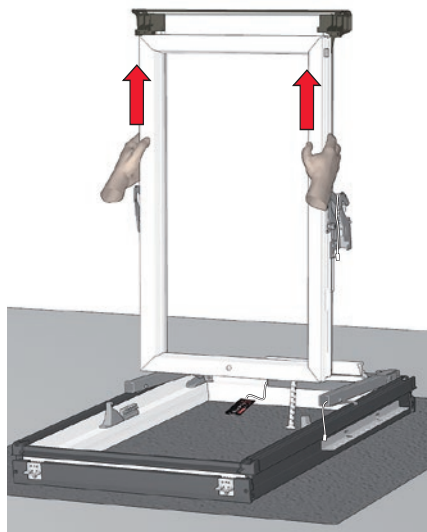

13

P



14

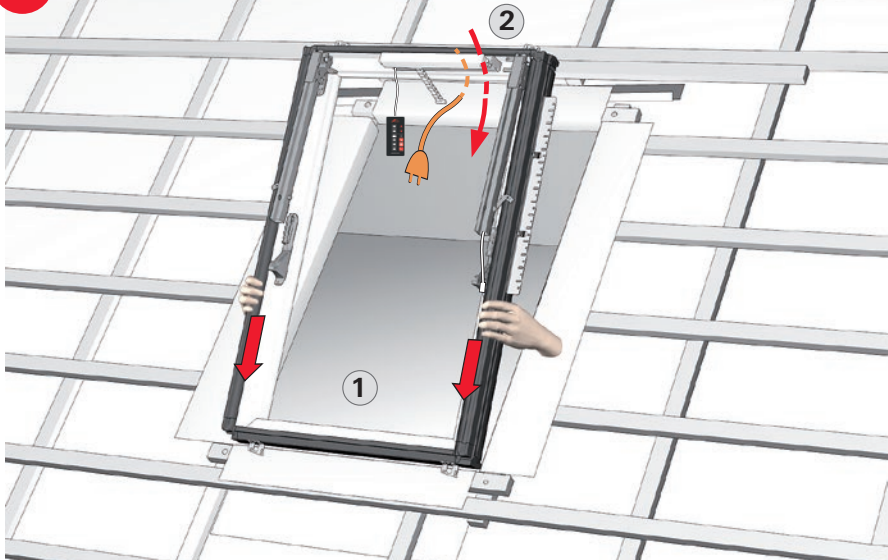



WDT R6x E



F 1x

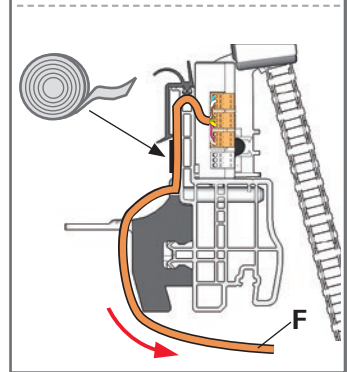
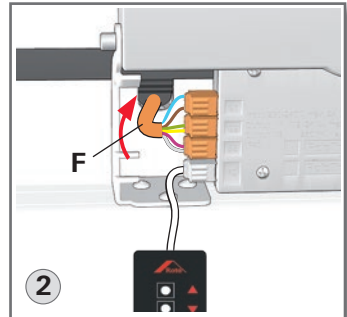
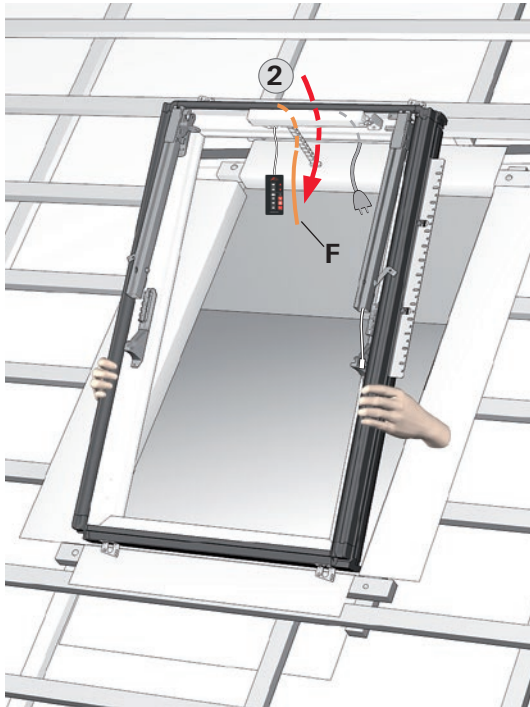
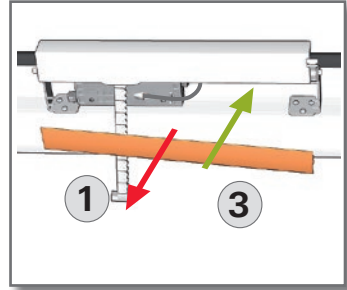
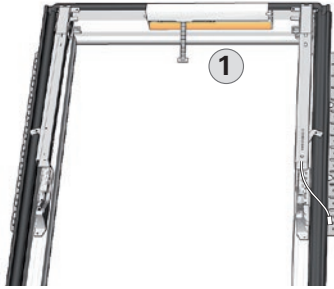

15



A 4x
ø4,0 x30

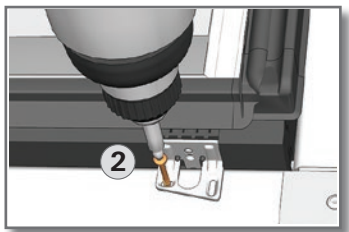
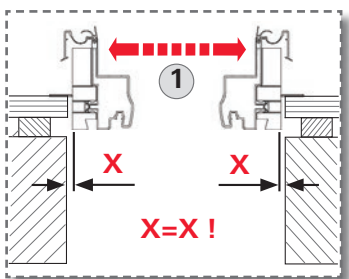
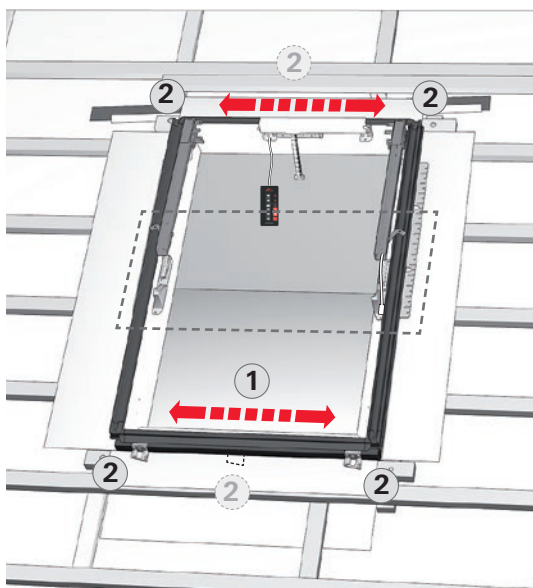

16

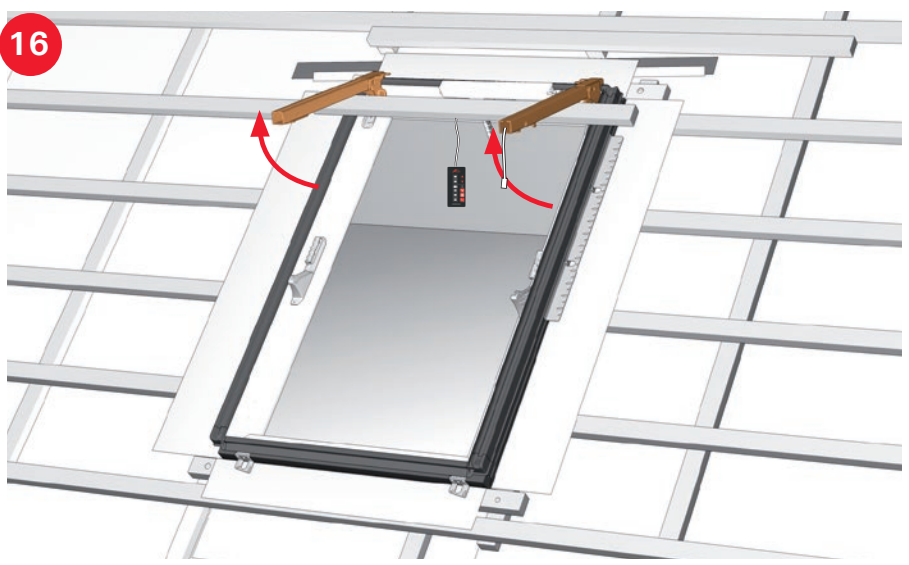

17

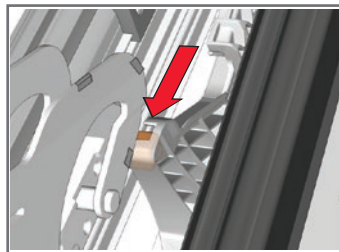
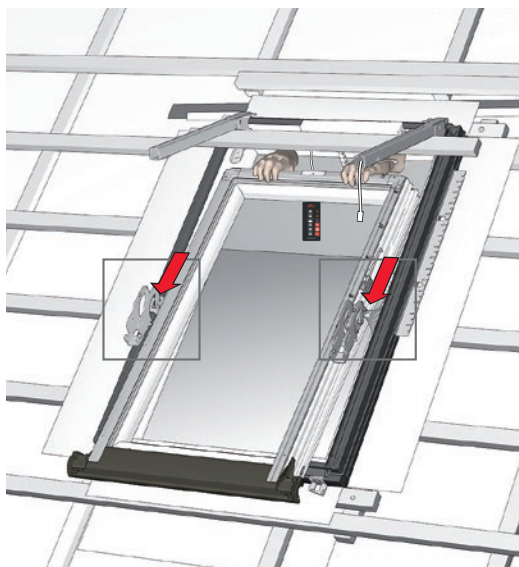
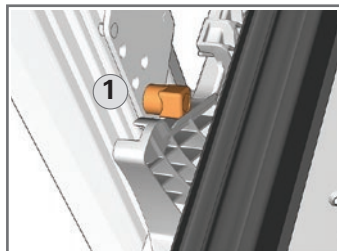
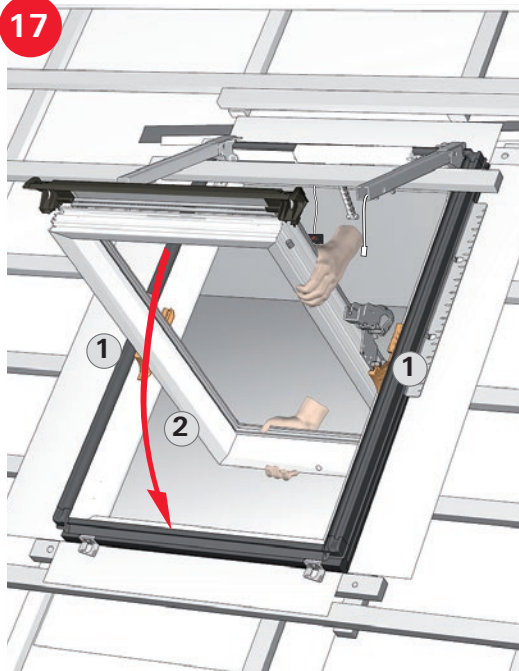

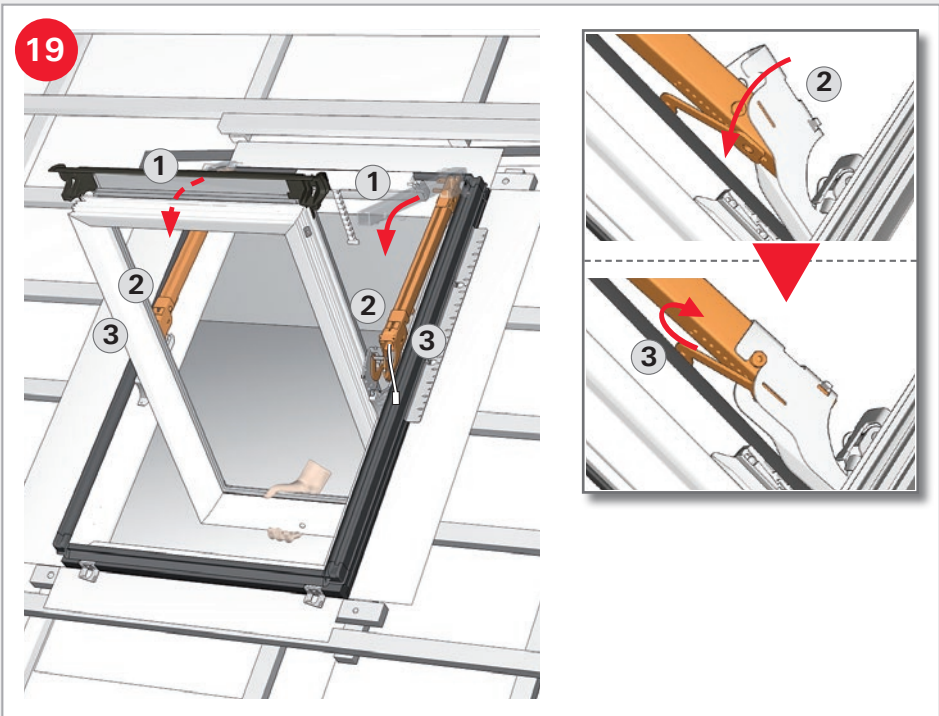
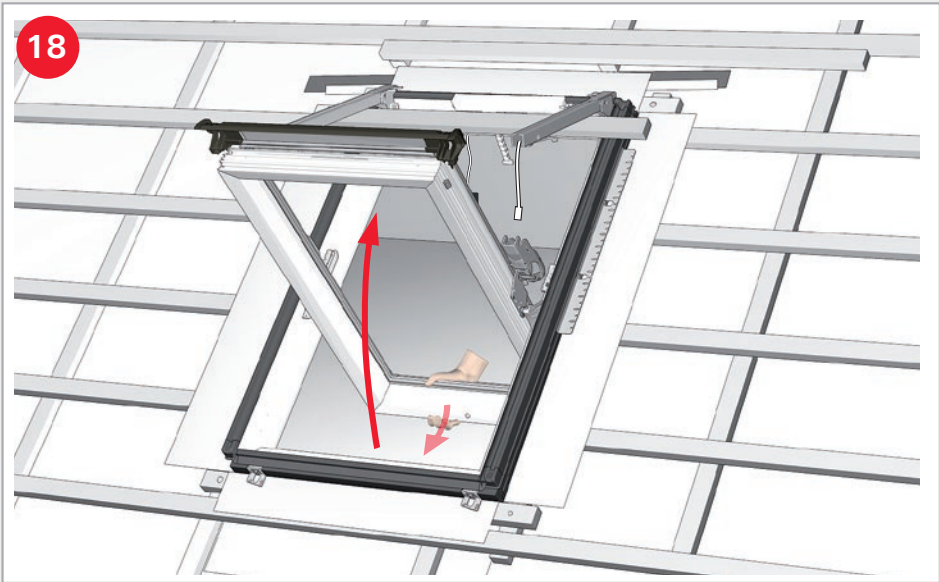

20

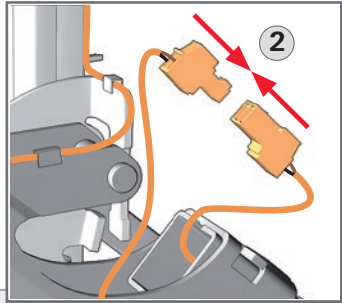
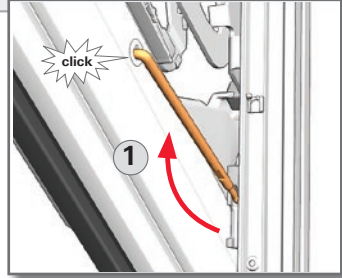
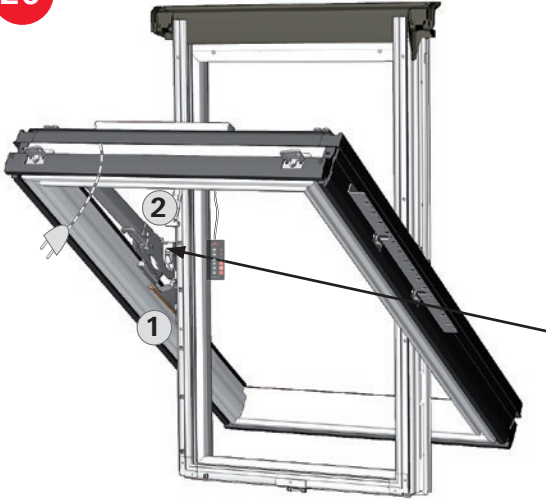

21

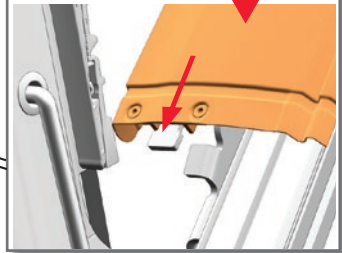
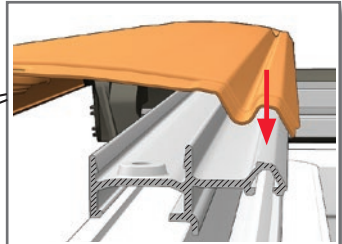
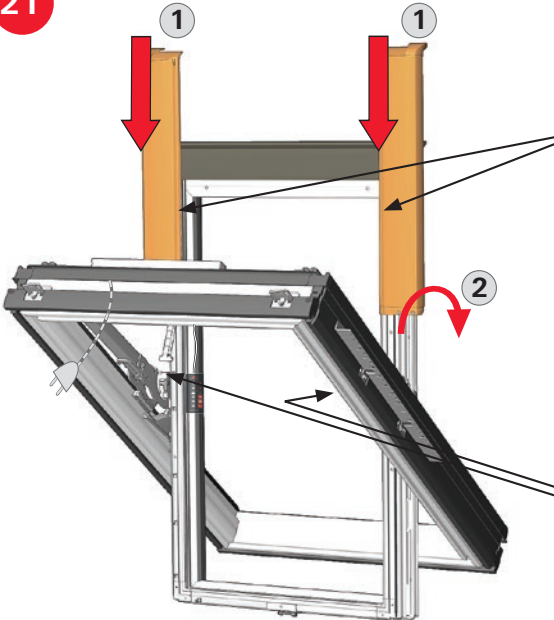

22



B 1x

OK ?

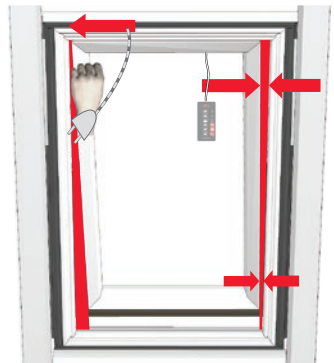
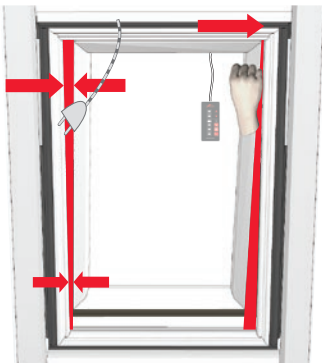
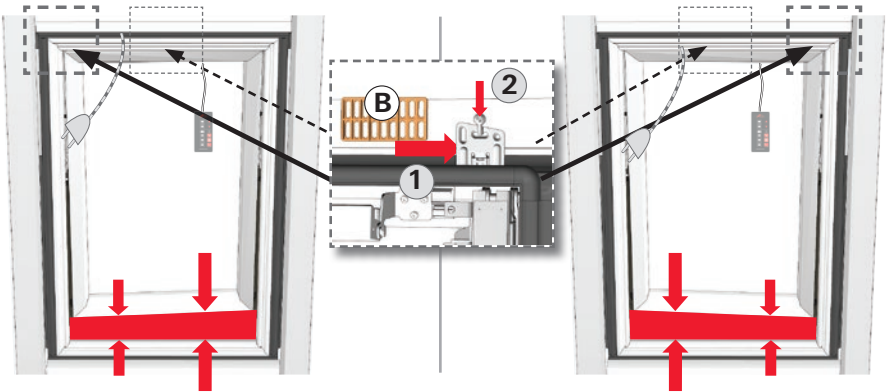
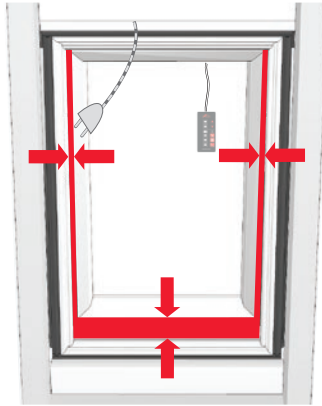

23

 **A 4x**
ø4,0 x30

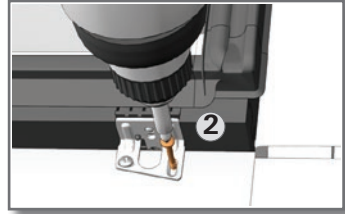
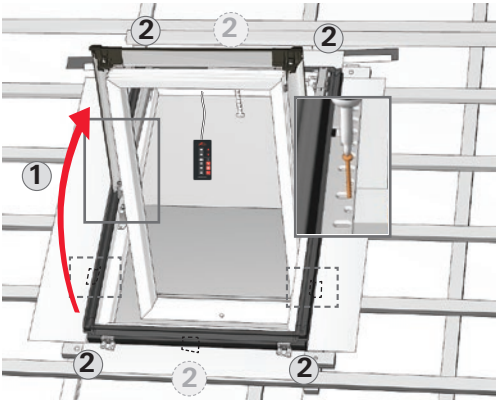

 **B 2x**

 **A 4x**
ø4,0 x30

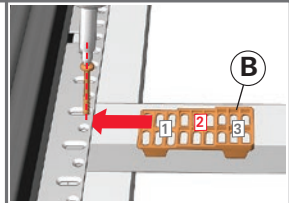

24

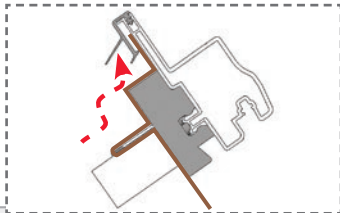
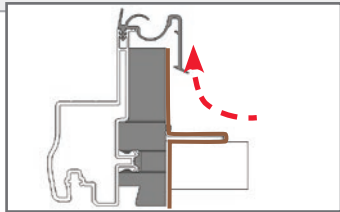
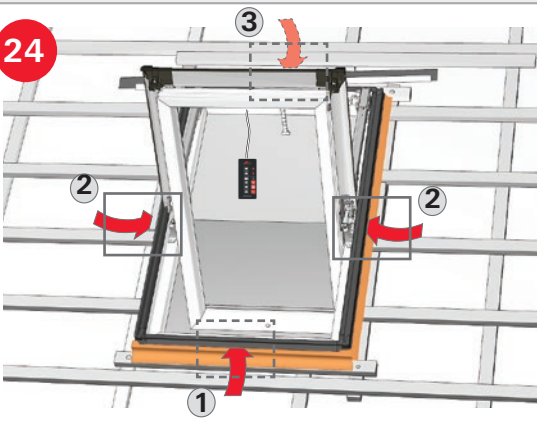

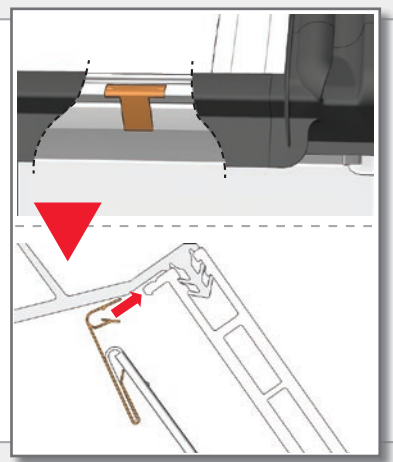
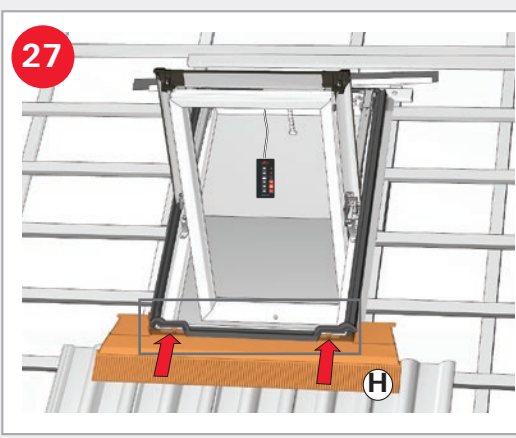
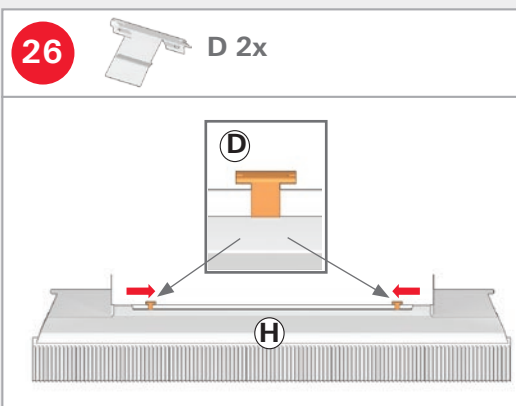
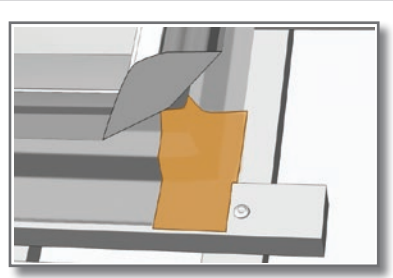
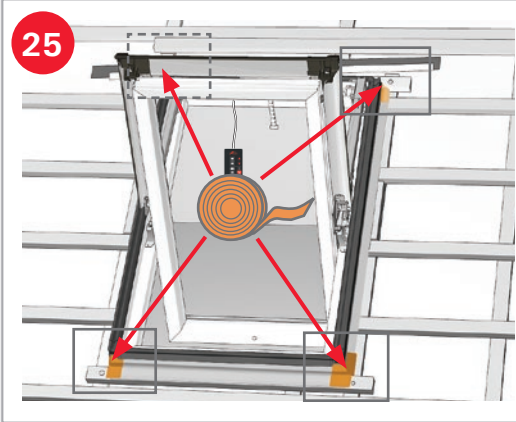

28



E 1x

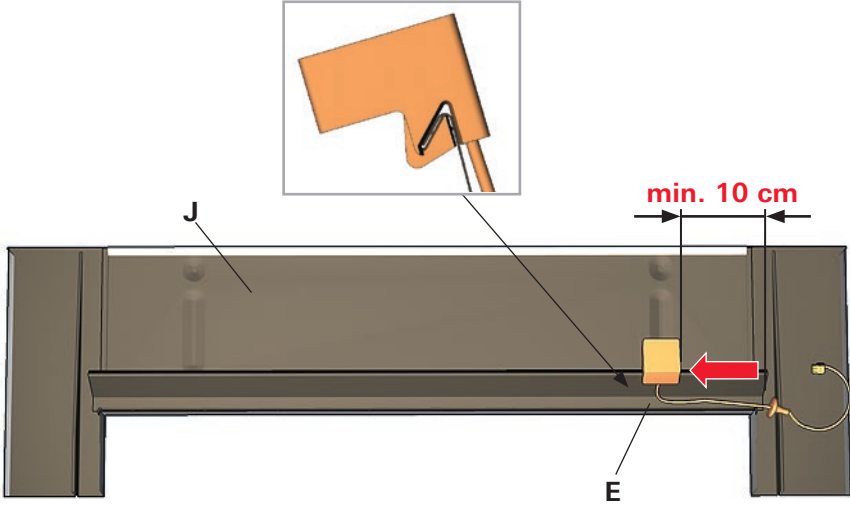

29

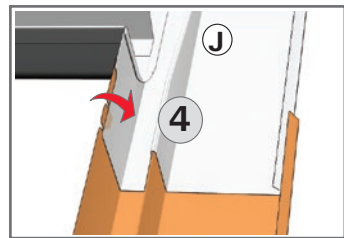
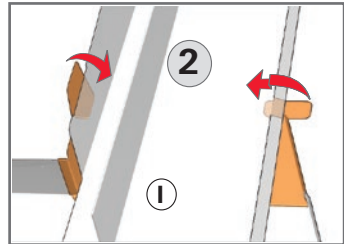
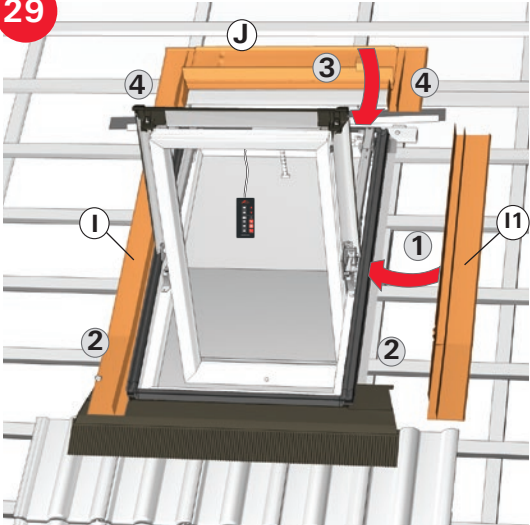

30

K 6x L 6x

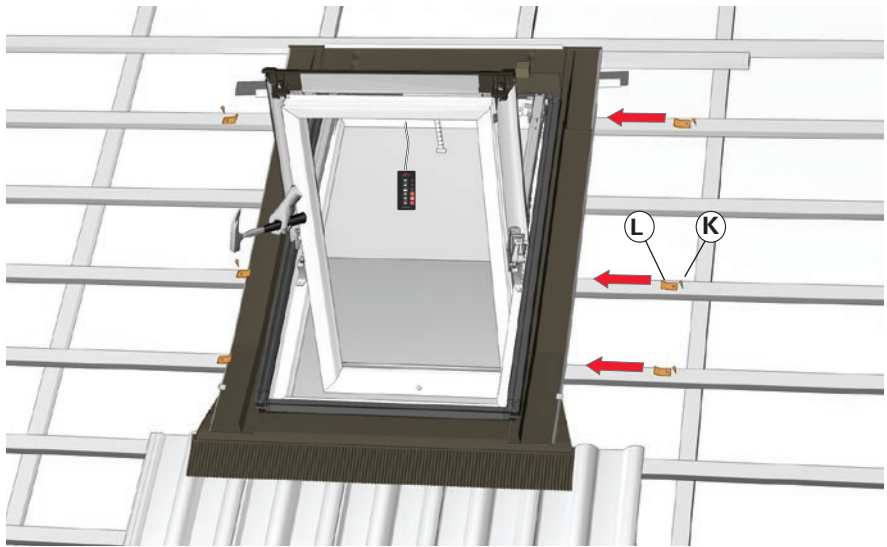

31

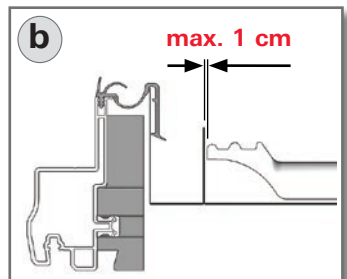
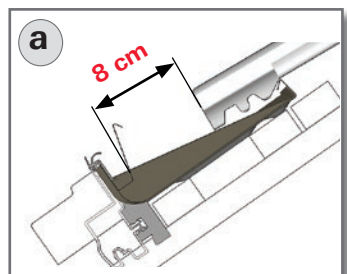
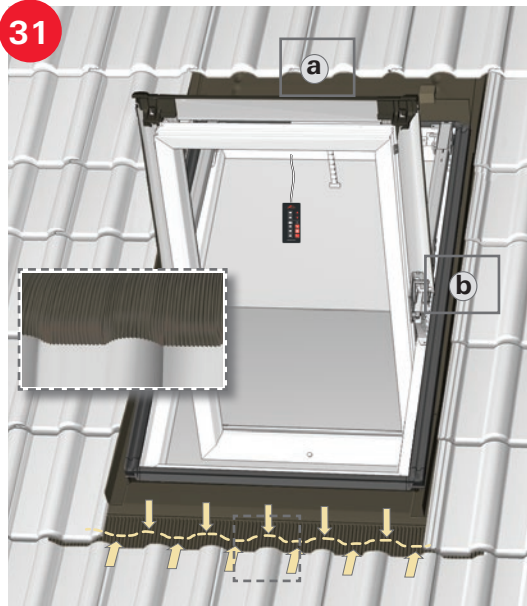

32

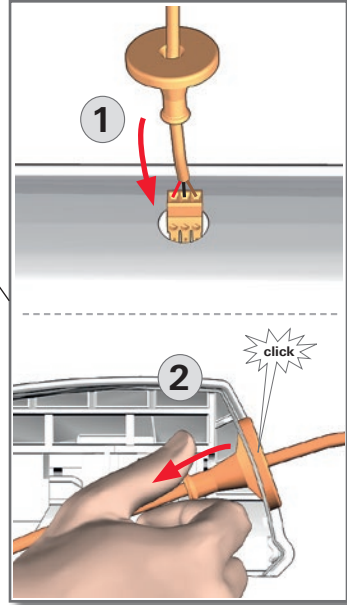
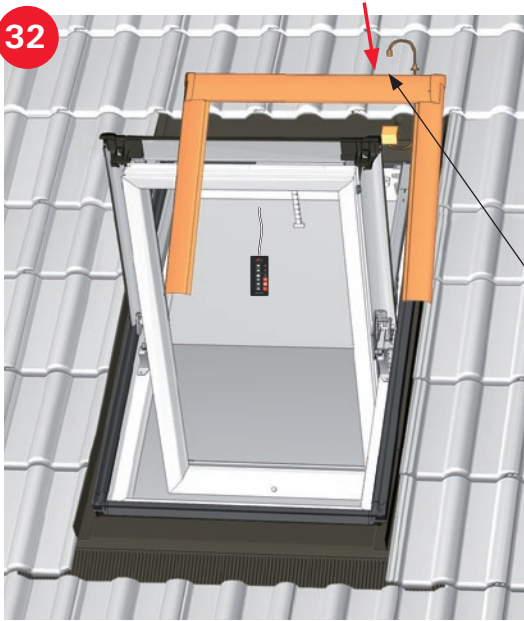

33

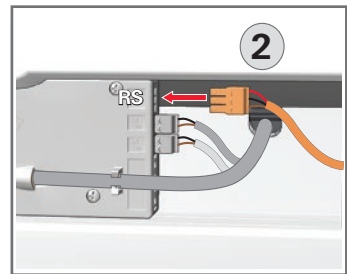
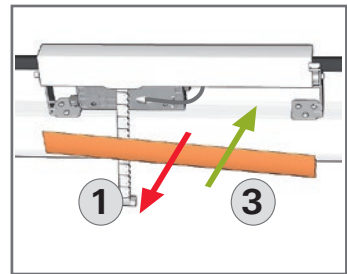
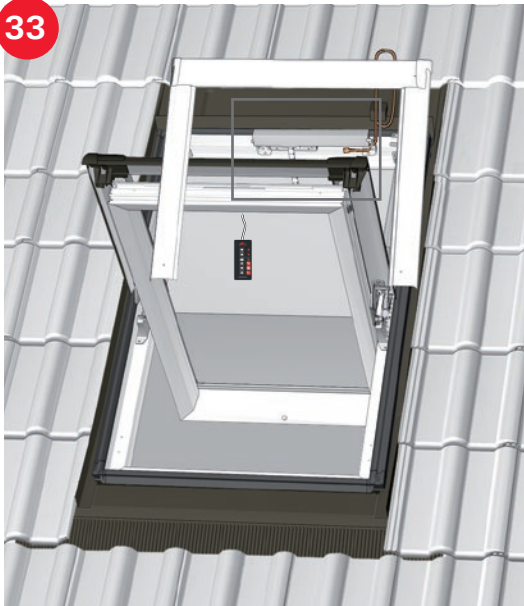

34

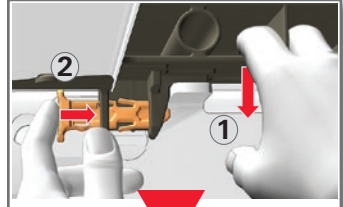
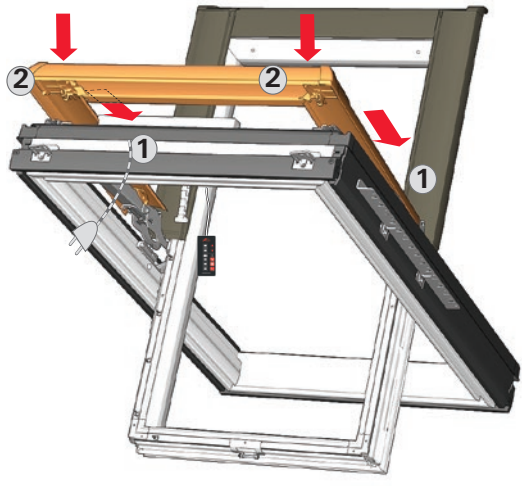

35

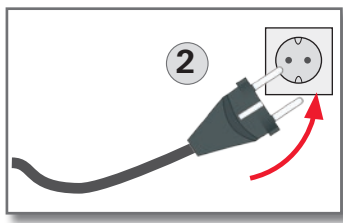
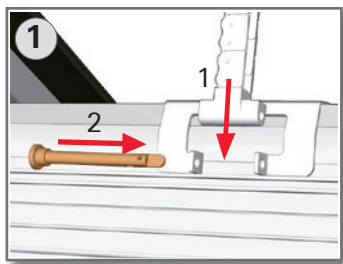
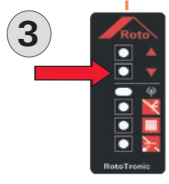
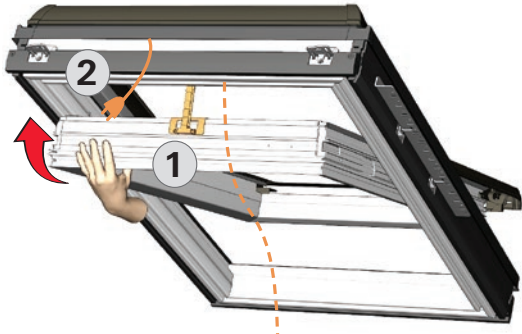

WDT R6x E



WDT R6x EF

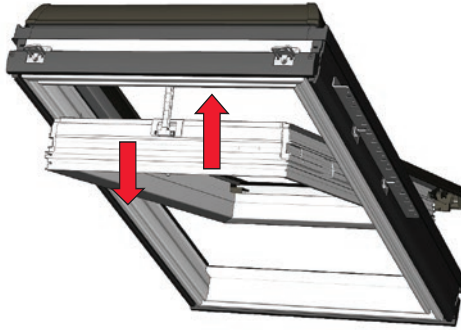

36

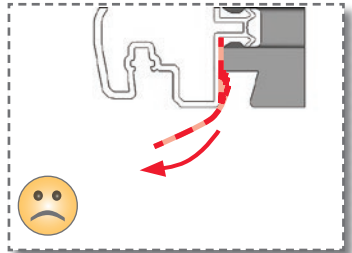
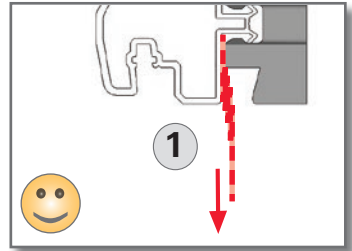
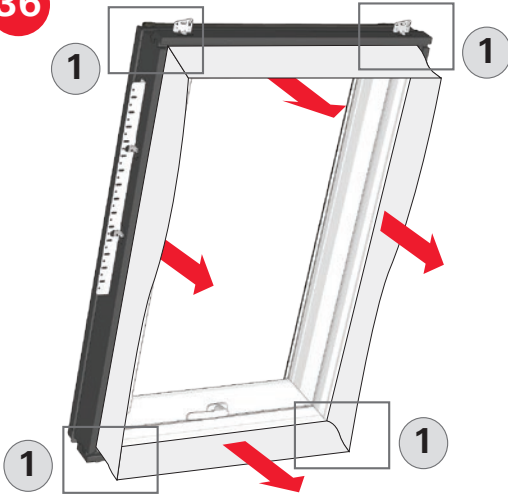

37

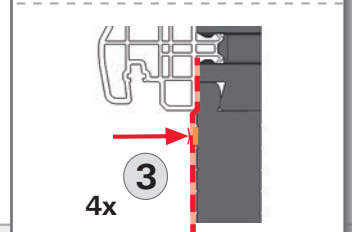
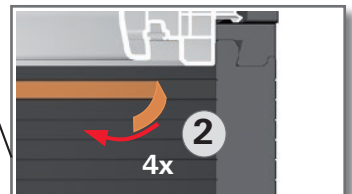
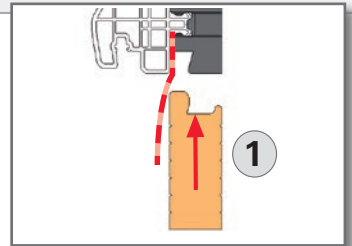
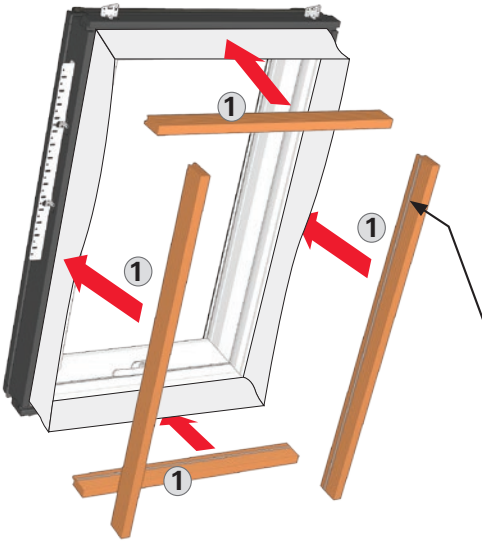

38

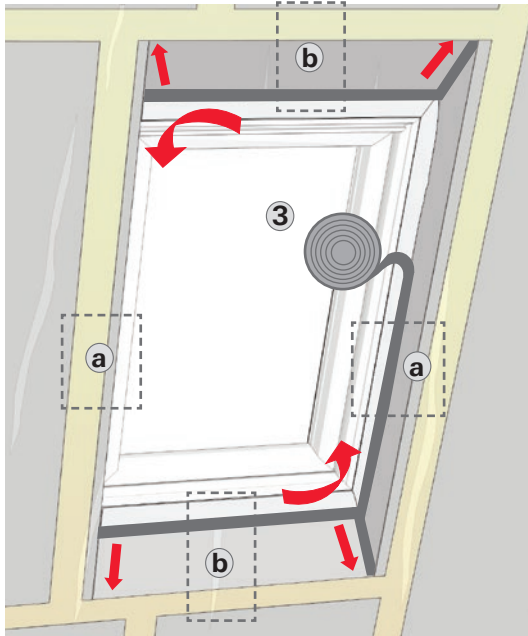

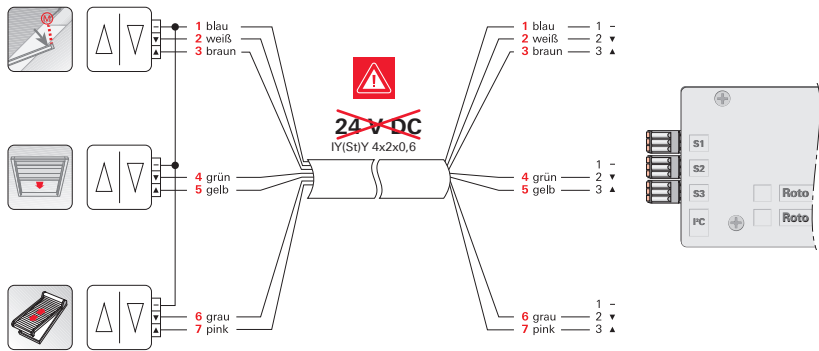

	1	2	3	4	5	6	7
	blau	weiß	braun	grün	gelb	grau	pink
	bleu	blanc	brun	vert	jaune	gris	rose
	blue	white	brown	green	yellow	grey	pink
	blauw	wit	bruin	groen	geel	grijs	roze
	azul	blanco	marrón	verde	amarillo	gris	rosa
	azul	branco	castanho	verde	amarelo	cinzento	cor-de-rosa
	niebieski	biały	brązowy	zielony	żółty	szary	różowy
	голубой	білий	коричневий	зелений	жёлтий	серый	розовий
	sinine	valge	pruun	roheline	kollane	hall	roosa
	zils	balts	brūns	zaļš	dzeltens	pelēks	sārts
	Žydra	balta	ruda	žalia	geltona	pilka	rožinė
	modrý	bílý	hnědý	zelený	žlutý	šedý	růžový
	modrý	biely	hnedý	zelený	žltý	šedý	ružový
	kék	fehér	barna	zöld	sárga	szürke	rózsaszín
	modra	bela	rjava	zelena	rumena	siva	roza
	Blu	Bianco	Marrone	Verde	Giallo	Grigio	Rosa
	plava	bijela	smeđa	zelena	žuta	siva	ružičasta
	albastru	alb	maro	verde	galben	gri	roz
	Μπλε	Λευκό	Καφέ	Πράσινο	Κίτρινο	Γκρι	Ρόζ

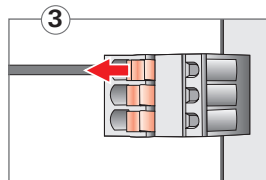
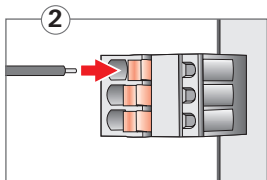
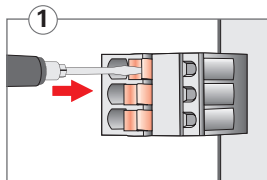

	Stift reindrücken und halten	Kabel in Buchse stecken	Stift loslassen
	Enfoncer la goupille et la maintenir	Enfoncer le câble dans la douille	Relâcher la goupille
	Push in the pin and keep it pushed in	Insert the cable into the socket	Release the pin
	Pen erin drukken en vasthouden	Kabel in bus steken	Pen loslaten
	Introducir el clavo presionándolo y mantenerlo en esa posición	Introducir el cable en el conector hembra	Soltar el clavo
	Pressionar o pino para dentro e segurar	Inserir o cabo na ficha	Soltar o pino
	Wcisnąć trzpieć i przytrzymać	Włożyć kabel do gniazda	Puścić trzpieć
	Вдавить и удерживать штифт	Вставить кабел в гнездо	Отпустить штифт
	Vajutage tihtvisse ja hoidke all	Pistke kaabel pesasse	Laske tihtv lahti
	leşpiediet tapu un pieturiet	leşieciel kabeli iemav	Atlaidiet tapu
	Pastumkíte ír laikykíte stryp	statykíte laid vör	Atleiskíte stryp
	Kolík vtlaťe a držte jej	Kabel zastrťe do zdíky	Kolík uvolníte
	Kolík zatlaťe dovnútra a podržte	Zastrťe kábel do zdierky	Kolík pustíte
	Nyomja be, és tartsa a csapós dugaszoló	Dugja be a kábelt a kapcsolóhelybe	Engedje el a dugaszolót
	Zati pritisnite in ga pridržite	Kabel vtaknite v pušo	Spustite zati
	Premere dentro la spina e mantenerla ferma	Inserire il cavo nella boccola	Rilasciare la spina
	Utisnite i držite klin	Utaknite kabel u uti nicu	Pustite klin
	se apasā tiftul i se iņe	se conectaezā cablul	se eliberazā tiftul
	Πέστε μέσα τον πείρο και κρατήστε τον	Βυσματώστε το καλώδιο στην υποδοχή	Αφήστε τον πείρο ελεύθερο



☎ +49 (0)7931 54 90 86 20
☎ +49 (0)7931 54 90 460
www.roto-frank.com



☎ +43 (0)2 75 42 11 99
☎ +43 (0)2 75 42 11 99 50
www.roto-frank.at | .si



☎ +41 (0)44 267 47 47
☎ +41 (0)44 267 47 46
www.roto-dachfenster.ch



☎ +33 (0)387 29 24 30
☎ +33 (0)387 91 49 01
www.roto-frank.fr



☎ +44 (0) 1788 558 600
☎ +44 (0) 1788 558 606
www.roto-frank.co.uk



☎ +353 (0)6 75 07 00
☎ +353 (0)6 73 46 31
www.careyglass.com



☎ +32 (0)67 89 41 30
☎ +32 (0)67 89 41 72
www.roto-frank.be



☎ +31 (0)800 0232 114
☎ +31 (0)800 0232 116
www.roto-frank.nl



ROTHISPANIA S. L. U.
☎ +34 98 152 69 39
www.rototejado.com



☎ (+351) 236 218 072
☎ (+351) 236 215 289
www.imporjan.com



☎ +48 81 855 05 22-25
☎ +48 81 855 05 28
www.roto.pl



MIZOL LTD
☎ +38 044 566 73 37
☎ +38 044 566 78 78
www.roto.ua



☎ +7 495 287 35 20
Kaliningrad
☎ +7 906 234 88 88
☎ +7 495 287 35 24
www.roto.ru



VTI-Invest
☎ +375 17 258 54 05
☎ +375 17 258 57 65
☎ +375 17 258 81 71
www.roto.by



☎ +359 889 93 96 96
☎ +359 32 55 01 99
www.buldach.com



☎ +420 272 651 428
☎ +420 271 750 187
www.roto-frank.cz | .sk



☎ +36 99 511 686/687
☎ +36 99 511 688
www.roto.hu



☎ +39 0421 618 211
☎ +39 0421 618 455
www.roto-frank.it



☎ +40 31 2281 5 86
☎ +40 31 2281 5 89
www.roto-romania.ro



☎ +30 231 0796 950
☎ +30 231 0796 783
www.eurotechnica.gr



rotainfo.ee@roto-frank.com
www.roto.ee



rotainfo.lv@roto-frank.com
www.roto.lv



info.lt@roto-frank.com
www.roto.lt



☎ +38 513 490 360
www.supera.hr



☎ +90 216 57 39 692
☎ +90 216 57 23 148